



Design & Build Your Own Flat- Bottomed Skiff

*By: Paul J. Bennett
Naval Architect/Marine
Engineer*

*© Copyright 2012/2021
All rights reserved*

Design & Build Your Own Flat-Bottomed Skiff

By: Paul J. Bennett

This booklet was originally designed and written by Paul J. Bennett as a curriculum for a local non-profit S.T.E.M. program for advanced middle school and high school students.

The goal was to inspire interest in young people to pursue studies and a career in my profession as a marine engineer and/or naval architect.

This is a considerably basic treatise regarding the subject of boat design and construction. It is not meant to make yacht designers out of any reader. Instead, it is my intention to simply whet your appetite on the subject and perhaps allow you to grasp a few principles at the very least.

This entire document is under copyright protection with all rights owned by me, Paul J. Bennett. This document may not be copied, sold, or redistributed by any media in any way without my express written permission and granted license to do so with the following exception:

Schools and institutes of learning, boating organizations with education & training elements, may reprint this document (only in its entirety) and distribute copies among students, providing it is done so at no cost to the student. Under no circumstances may it be sold for any amount of money.

I presently publish numerous “how-to” videos on YouTube under two separate YouTube channels:

“Downeast Thunder Creations” is an eclectic mix of subject matter – many projects off free plans in pdf format.

“Shoestring Shipyard” is exclusively boat project related. Again, there are several free plans offered in pdf format you can download.

Several articles and plans are also available on my website: <https://www.downeastthunder.com/>

My other website is: <https://www.shoestringshipyard.com/>

Not everyone is a naval architect or wishes to become one, yet it is not a necessary requirement to be a naval architect in order to design your own small dinghy. Very simple methods using very basic math can be used to design small skiffs by the layperson with excellent results. This is generally the path taken by those not satisfied with the myriad selection of designs presently offered to the public. Others simply enjoy being self sufficient.

Perhaps you might be one of them.

Maybe you can design your own boat the way you want it to be.

As long as we stay within the genre of simple, flat bottomed skiff designs, or “flatties” as they were once widely referred to, I can guide you through the design process. You don’t have to become a naval architect or marine engineer to do this. I’ll show you how to develop your boat using simple drawings, paper models, simple grade school math, and maybe a little common sense.

Some folks may ask if this is how I develop Shoestring Shipyard designs. The answer is no, I don’t. I use hull development software on a computer, CAD software for construction drawings, math shortcuts utilizing calculus and differential equations to work various problems, and I refer to books filled with charts, graphs, and tables of pre-calculated data to save time.

The remainder of this guide contains all of the information you need to calculate the materials needed, weight of the hull, and actual construction process to build your own design full size. I’m only going to stick with small dinghies under the overall length of 8’ as there is less chance you’ll get into trouble with your first design. Larger craft requires some engineering well beyond the scope of the intentions for this project. If this section sparks your interest and you would like to pursue further knowledge in boat design, there are several publications listed in the bibliography at the back of this guide.

Before getting into the nuts & bolts of your new boat design, there are a few basic ideas & principles you need to understand or at least be aware of. Going over these now will allow you to better understand and “see” what is taking place when determining how your boat hull will be developed.

Buoyancy

You can call it buoyancy or floatation, but physicists, scientists, and engineers, refer to this phenomenon as Archimedes’ Principle.

Archimedes was a Greek guy who lived around 2300 years ago (or so). He was the curious type and studied various physical actions and reactions taking place in nature to learn about how and why things happened. This curiosity made him a scientist and/or physicist of his day.

His curiosity, experiments, and findings as to why objects float on a surface of water is what made him famous, and thus called “Archimedes’ Principle.” My explanation of this principle is oversimplified and brief. There is no need to go into an exhaustive study on the subject. My goal is to give you a basic understanding as to why boats float on the water.

Archimedes’ Principle: An object that floats when placed in a body of water is floating due to upward pressure from the water against the object that is equal to the downward force created by the weight of the object. That statement is relatively simple, yet appears to be complicated when trying to picture what is happening in one’s mind. Perhaps a simpler explanation would be to say that when an object is placed in water and it floats, the cubic displacement of the object below the surface of the water is equal in weight to the amount of water it displaces.

Still a little fuzzy?

DWG# EX-001

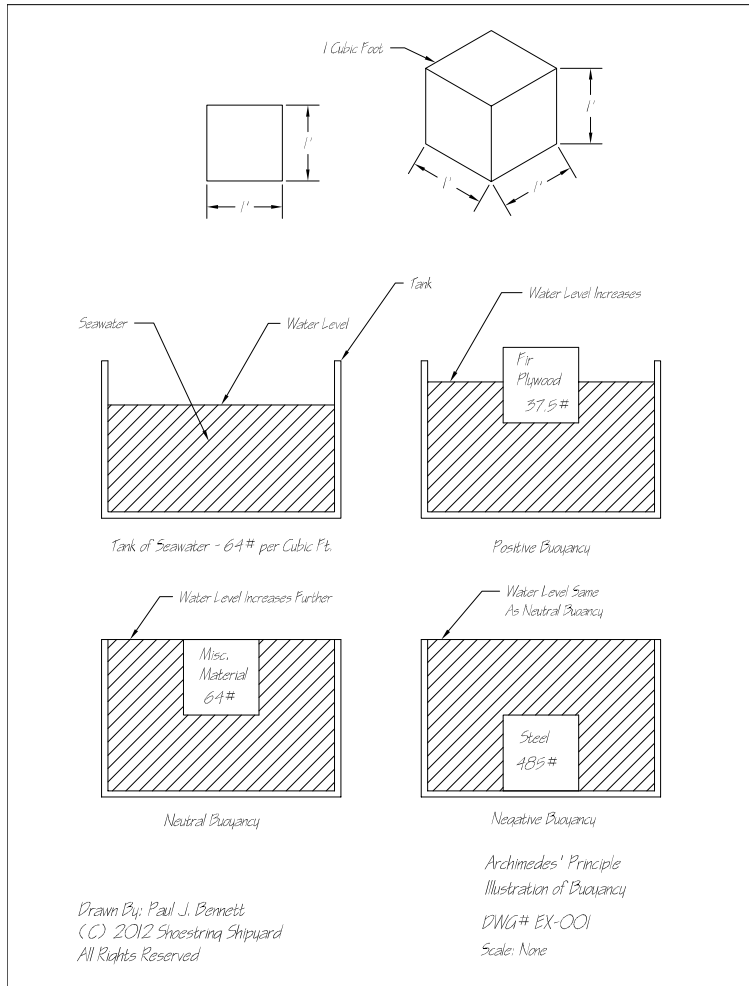

Let's say that sea water is about 64 pounds per cubic foot (a cubic foot measures 12" wide x 12" long x 12" high). Any object that weighs less than 64 pounds per cubic foot will float or have what we call positive buoyancy because the water has greater density and therefore applies greater pressure on the object than the object is applying to the water, therefore holding the object up, with some of the object above the surface of the water.

If the object placed in the water displaces one cubic foot and weighs the same as sea water at 64 pounds per cubic foot, it is said to have neutral buoyancy. It will neither sink, nor float, but "hover" or stay in whatever positions it may be placed within the water. This is a theoretical situation because it is almost impossible to achieve neutral buoyancy for any given time because the density of water changes with depth and temperature.

If the object placed in the water displaces one cubic foot but is made of solid steel with a weight of around 485 pounds per cubic foot, what happens? The object has much greater density than the sea water, and therefore the sea water pressure is not sufficient to support the object. The object then sinks straight to the bot-

tom. This is referred to as negative buoyancy.

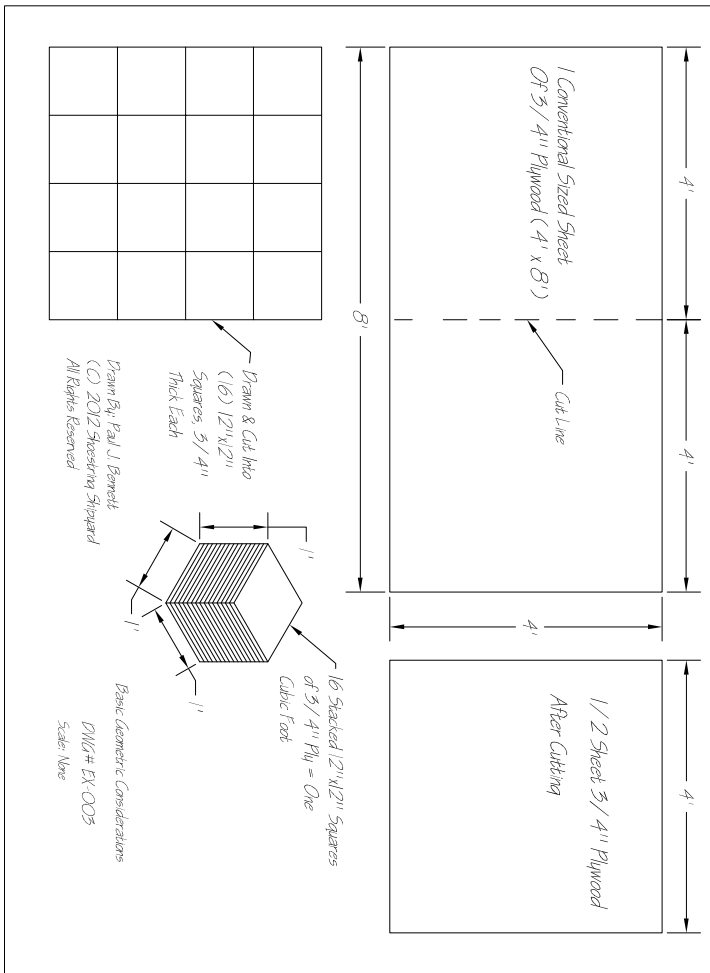

Now to apply Archimedes' Principle in a practical example: Elsewhere in this guide, you'll note a sheet of 3/4" fir plywood weighs about 75 pounds. A standard sized sheet of plywood regardless of thickness measures 4' wide by 8' long and contains 32 square feet in area. It takes 16 square feet (half a sheet of 3/4" plywood) to make up 144 cubic inches (or 1 cubic foot) of volume. If we cut half a sheet of plywood into 16 squares of 12" x 12" x 3/4" and stack them up with glue to make one cubic foot of fir plywood measuring 12" x 12" x 12" the total weight should be about 37-1/2 pounds.

Will this object float with positive buoyancy? Will it hang wherever it is placed in the water with neutral buoyancy? Will it sink to the bottom with negative buoyancy?

The object you just fabricated has positive buoyancy because it has less density/weight than sea water, therefore it will float. That's great, but how much weight will it support before it reaches the point at which it will sink? This is easy to calculate and is in fact how we quantify the degree of buoyancy the object possesses.

Simply subtract the weight of the object (37-1/2 pounds) from the weight of sea water for the same displacement (64 pounds per 1 cubic foot of displacement) and that

gives you 26-1/2 pounds of buoyancy or floatation. That means you can add another 26-1/2 pounds to the object to the point of where it achieves a state of neutral buoyancy. A little less weight added to the object, and the object remains afloat. A little more weight than 26-1/2 pounds added to the object, and the object will have negative buoyancy and sink.

The example above used a solid cube of wood. The next example is more practical. I'll still use one cubic foot measuring 12" x 12" x 12" and using 3/4" plywood in order to reduce the possibility of confusion. The difference is the object will be hollow. It will have a 3/4" thick plywood bottom and sides, but the top will be open and the core of the cube will be empty. Essentially this is a small boat in the shape of a cube. How much buoyancy will it have? That is to say; how much will it hold? A small hint: More than the solid cube of wood.

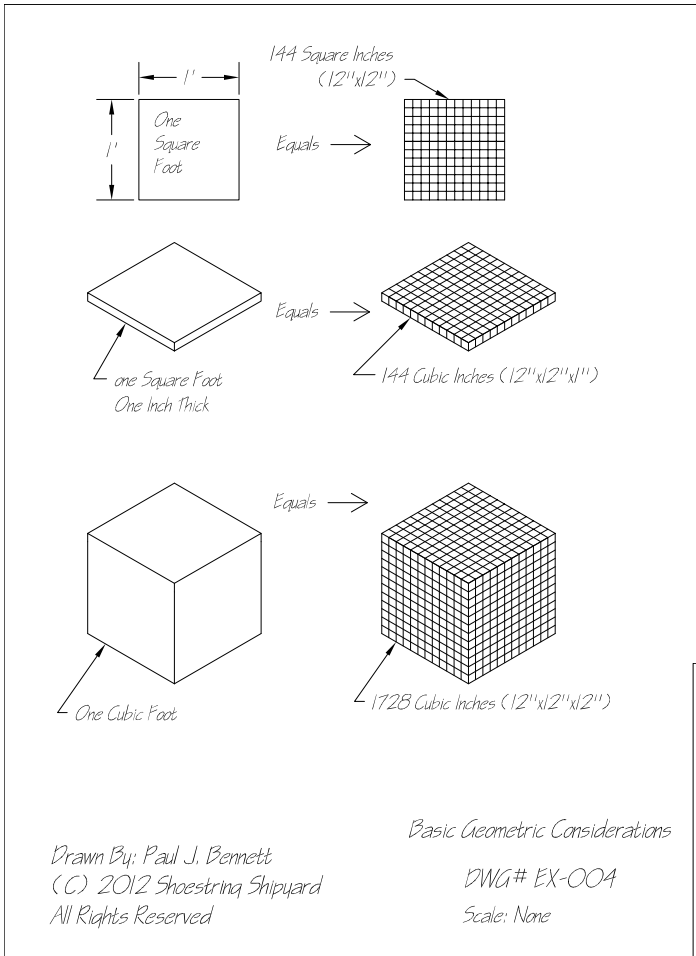

DWG# EX-004

Before beginning calculations, it's a good idea to list given information and conventions to avoid confusion and to help with the logical thought process:

We are dealing with a displacement of one cubic foot measuring 12" x 12" x 12" and one cubic foot equals 1728 cubic inches (12" x 12" = 144 square inches, and 12" x 144 square inches = 1728 cubic inches). We are going to calculate the cubic displacement of the plywood material used in the construction of our little cube shaped boat, and it is 3/4" thick and we believe it weighs 37.5 pounds per cubic foot or per 1728 cubic inches. 37.5 pounds divided by 1728 cubic inches is approximately .022 pounds per cubic inch.

DWG# EX-002

The base of the boat measures 12" x 12" and two sides measure 11.25" x 12" (allowing for the thickness of the bottom) and the other two sides measure 10.5" x 11.25" (allowing for the thickness of the bottom and the thickness of the first two sides).

The equation for the cubic inch displacement of the wood used in the small cube boat is as follows:

$$(.75")[(12" \times 12") + (2)(11.25" \times 12") + (2)(10.5" \times 11.25")] = \text{cubic inches (note the .75" is the thickness of the } \frac{3}{4} \text{ plywood in decimal form).}$$

Simplified:

$$(.75") [144 \text{sq.in.} + (2)(135 \text{sq.in.}) + (2)(118.125 \text{sq.in.})] = \text{cubic inches}$$

Further simplification:

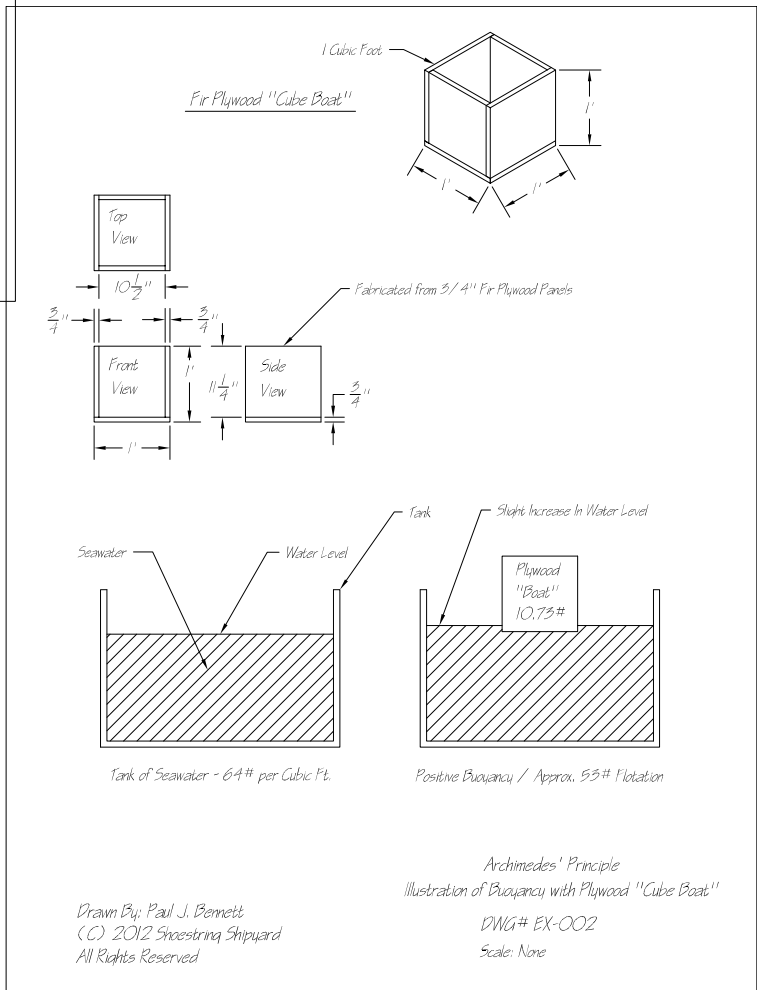

$(.75'')(144\text{sq.in.} + 270\text{sq.in.} + 236.25\text{sq.in.}) = (.75'')(650.35\text{sq.in.}) = 487.69$ cubic inches.

487.69 cubic inches of plywood multiplied by .022 pounds per cubic inch of $\frac{3}{4}$ " plywood = 10.73 pounds. This is the weight of our cube shaped boat which just happens to have the same dimensions and cubic displacement as one cubic foot of water.

If one cubic foot of sea water weighs 64 pounds, and we subtract 10.73 pounds (the weight of our boat), we have 53.27 pounds of buoyancy or flotation. To further simplify, we can round off to the nearest whole number and say we have 53 pounds of flotation (our total load capacity).

You can roughly calculate the displacement and weight of your dinghy design in much the same fashion and I'll show you some more examples with illustrations later on. You won't have to be exact. You really only need an approximate figure near the ballpark (so to speak) for such a small vessel.

Hydrodynamics and Fluid Mechanics

The two terms; hydrodynamics and fluid mechanics are used synonymously by many and there are others claiming the two to be separate fields of study. They really break down into specialty areas of physics. Essentially, I'm describing the properties and effects of fluids at various temperatures and viscosities. From these studies, one can easily branch into hydraulics and aerodynamics. Almost everything in science is interrelated in some form or another.

For the purposes of designing a small dinghy, I'm not going to write voluminous amounts of text on the subject. I just want to familiarize you with some of the considerations that go into boat design and explain some basic concepts to bring about an understanding as to why vessels share similar shapes, and why boats are designed they way they are.

The biggest conventions I hope you'll grasp are turbulent flow and laminar flow. That is to say water flow around a stationary object, or a dynamic object moving through the water. We can quantify, evaluate, calculate, and predict both types of flow characteristics. We can calculate resistance to flow and determine energy requirements to overcome this resistance. With flat bottomed boats (essentially hydroplanes) we can calculate the energy and speed required to lift the hull up and position itself right above the surface of the water on a bed of air bubbles. We call this phenomenon "coming up on plane."

We don't have to go this far with small dinghies. However it is good to know the differences in flow characteristics, and why a little bit of shape at various points in the hull can help it move through the water much easier with less effort than it may require otherwise.

Basically, turbulent flow is when fluid meets with substantial resistance when trying to move past an object sitting on or in that fluid. A good example that most people will readily understand is if you move your open hand through a tub of water somewhat like a paddle. You can feel significant resistance of the water against your hand. The faster you move your hand through the water, the more resistance you can feel.

Laminar flow is the opposite of turbulent flow. Laminar flow is very smooth and objects designed to achieve this flow characteristic appear aerodynamic in shape and offer the least amount of resistance. To understand this concept, run your open hand through a tub of water again, but this time hold your hand sideways such that the water is only going past the edge of your hand with a much smaller surface area and rounded edge. Notice how much less resistance there is and how much less an effort it requires? Even repeating the process at higher speed, the resistance is only slightly increased.

This relates to boat design in a number of ways. You may have noticed most vessels have a “pointy” bow. This is on the surface, but it allows the vessel to have less wind resistance and also helps the vessel to navigate through waves without being stopped or pushed backwards. The requirements for energy to overcome wind and waves are thus reduced as well.

Under the surface of the water is another matter. We don't want to “push” against the water (turbulent flow), so we add a bit of “rocker” to the bottom of the boat (please note I am only relating design considerations to small dinghies under 8' and not to all types and sizes of vessels). The rocker in the hull is an upswept curve from somewhere around amidships to the bow such that the bottom of the stem at the bow is just barely above the water surface. This allows the hull to lift easier and with less power to come up on plane with a small outboard, and to slip through the water with less effort when rowing or under sail. For models intended only for outboard use, that is the extent of the rocker in most designs. In dinghies intended mostly for rowing and sailing, the rocker extends with an upswept curve going aft such that the bottom of the transom at the stern is just barely above the water surface. This reduces drag which is essentially resistance to flow. When rocker is extended to the stern in a vessel designed for outboard power, the vessel has a tendency to “squat” while under power. The angle of the outboard may be adjusted to compensate and help trim the boat, but not usually enough. Therefore, outboards used on dinghies designed primarily for rowing and sailing need only be at very low horsepower ratings and/or operated at very low speeds to reduce the squat tendencies.

You may also note the beam at the stern is substantially less than the maximum beam somewhere near amidships. The reason for this is also for reducing the surface area in contact with the water at the aft end of the boat thus reducing drag and achieving greater laminar flow characteristics. On dinghies designed strictly for outboard use, you may see the maximum beam at the transom or at least very close to help achieve the hydroplane effect.

These are the most prominent points I wanted to bring to your attention. I have not discussed stability and trim, center of gravity, or center of effort. I have not discussed moments or other conventions normally used in boat design. Stability in a small dinghy is largely achieved by crew positioning and moving gear about where needed. As long as the dinghy is symmetrical and designed fairly close to conventional craft similar in size, the math exercise is not really needed. I didn't want to get into the other conventions mentioned as they too are not as critical in small dinghies under 8' as they are in larger craft. The idea is to keep this exercise simple, clear and concise. I want you to become interested, perhaps inspired to try your own design. If you learn enough here to whet your interest in science and engineering, I've done my job.

My next discussion has to do with generating and fine tuning your basic dinghy design, starting with the basics of course, leading to a final hull shape you are happy with. My Simple Simon design will be used throughout for examples.

Early Boat Design

From the earliest dates when humans began building watercraft, boats were built by eye and from memory by master craftsmen. Apprentices would study and work with the master through the creation of several vessels over many years until they themselves became a master shipwright. The shipwright may remember general, overall dimensions, but no two vessels were ever built anything alike.

Within the last few hundred years, shipwrights learned they could carve and shape a scale model hull from solid wood to their liking. From this model, they could take off the measurements at regular intervals (called stations) and the lines and measurements were transferred to what was referred to as a loft floor in full size. There were bound to be a few mistakes which might cause an unfair curve, so the curve would be faired with the use of a flexible wood batten bent around the various measurement points. This exercise was called lofting and fairing. This is a practice

that lasted until very recent times, and is still in used in many small traditional wooden boat shops.

Not all that long ago, some shipwrights began to specialize in boat design. They became specialized engineers we refer to as naval architects today. Naval architects began designing vessels by drawing shapes and pictures on paper. The drawings were drawn to a specific scale and the drawings were then sent to a loftsmen, a specialized draftsman who would transfer the drawings and measurements into a full sized drawing on a loft floor as was deemed conventional practice by then. The curves were checked by eye and faired with flexible battens as they were in older times. Again, this practice is still used in many small shipyards and boatyards today.

The biggest difference between taking measurements from a model which was three dimensional, and a paper drawing which is two dimensional out of necessity, is some method had to be developed to represent the three dimensional shape of the hull on a two dimensional surface. This was accomplished through a series of lines drawn in three different planes, displayed in 3 different views. A table was developed to show these measurements and was called the table of offsets.

Today, designs are chiefly generated with the use of specialized, three dimensional hull software, and with detail drawings generated using CAD programs. The drawings tend to be more precise and the lofting for the purpose of fairing curves is no longer necessary (although a table of offsets is still usually generated).

I'm going to take you back to the "Dark Ages" for the purpose of designing your dinghy. My method chosen for your design experience goes a little backward and forward in terms of technology, as we are designing for the use of modern boat building materials and techniques.

For materials, I want you to stick with plywood. You can use marine grade fir for the full sized hull, or you can use AC-Exterior (ACX) grade fir plywood. Marine grade has a solid core and excellent faces on both sides. ACX has many hollows in the core layers and an imperfect face with some knots/voids on one side. If using ACX plywood, use the "A" or good side for the outside of the boat hull.

For scantlings (materials specifications); I suggest using $\frac{3}{4}$ " plywood for the transom, $\frac{3}{8}$ " plywood for the bottom panel, and $\frac{1}{4}$ " plywood for the side panels. If you stick with these scantlings, your dinghy will be quite strong and sturdy.

If you look at the materials lists for my other 8' dinghy designs, you'll get an idea of what you might specify for scantlings for the remainder of your boat and I'm going to leave that all up to you. That's part of the fun of designing your own boat.

We'll start by developing a boat shape using card stock or poster board, drawn as plywood panels in scale size. If you use a scale of 1"=1' (1/12th scale) you can use card stock, but you should use at least poster board or something heavier for larger scales such as 1-1/2"=1' (1/8th scale) or larger. The card stock would be too flimsy for anything beyond 1/12th scale.

The other materials and items you'll need are several sharpened pencils and erasers, a pair of scissors, cellophane tape, and an Architect's Scale. An Architect's Scale is a three sided rule with a variety of scales printed on both faces of each edge (six scales). The Architect's Scale allows you to scale items in common scales using conventional fractions of an inch for measurements under one inch.

An Engineer's Scale looks very much like an Architect's Scale, but the different scales are graduated in tenths of an inch and are not appropriate for this exercise. When you purchase your scale, double check to see if it is for architects or engineers – it will be printed directly on the scale itself. They are usually sold together so it's easy to mix

them up. Also make sure you look for a “students” version of the scale as they are less than half the cost of the professional versions, but just as accurate. They can be found for only a few dollars at most stationary/office supply stores.

Designing in Stages

You will develop your dinghy design in a few stages by building card stock models in different shapes to get where you have a design you might be interested in developing further. For the card stock models, we are only interested in developing hull shape, therefore it is not necessary to cut out and affix a bottom panel to the model.

Once a card stock model is developed to your satisfaction, you will then build a larger scale model in wood with glue, and paint the hull in the color(s) you would like to see the full sized boat. This time, you will be fitting a bottom panel and I recommend building the wood scale model in a 3”=1’ scale (1/4th scale). Very thin luan panels used for making hollow interior doors (sometimes referred to as “door skins”) might be available through your local lumberyard, probably on special order. You can also purchase thin basswood panels from a hobby shop, but it will be much more expensive.

After the large scale model is built, you can take measurements (offsets) from the hull and duplicate them in the form of a drawing you can use to help build the full sized version later. The large scale version will make a great reference tool while building the full sized hull too. After the bigger boat is finished, your wood model might earn a place on a trophy case or other display area.

The first stage is not really a design, but a beginning in the basics. This is not a boat you would want to build or own. There is no rake on the ends, rocker on the bottom, or flare on the sides. Nope. This boat has a plumb transom, plumb bow, plumb sides, and absolutely flat bottom. It’s pretty “ho-hum” if you ask me, but it is a start and is the basis of Simple Simon. I’m going to call this first one “Plain Jane.”

DWG# EX-005

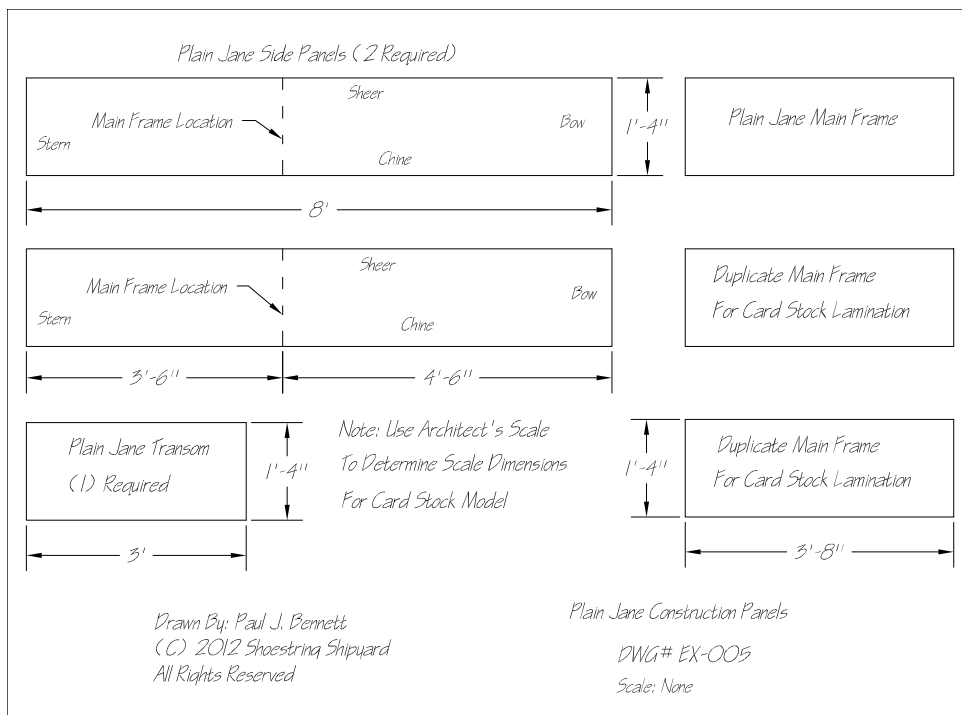

Start by using your architect’s scale and look for the scale with a “1” printed on the end. This is the 1”=1’ scale. The width of the side panel you are going to draw will be 1’4” in full size, so draw a 1’4” vertical line on your card stock using the scale. The panel is 8’ long so when you use a 1/12th scale, the horizontal line will be an actual 8” long (but will be 8’ on the scale). Complete the rectangle then draw one more so you have two side panels in scale size.

The two rectangles you have cut out are indeed the side panels for Plain Jane in 1/12th scale. Now measure 3'6" from one end, or 4'6" from the other end. Draw a perpendicular line from the bottom of the panel, extending to the top. Mark this line; main frame location. At the end with the longest distance from the main frame location line, use a pencil and write; bow. At the opposite end, write; stern. Then label the bottom edge of the panel as the chine, and the top edge of the panel as the sheer. Repeat this same operation for the other side panel. You'll begin to understand why you are doing this during the assembly of the hull model.

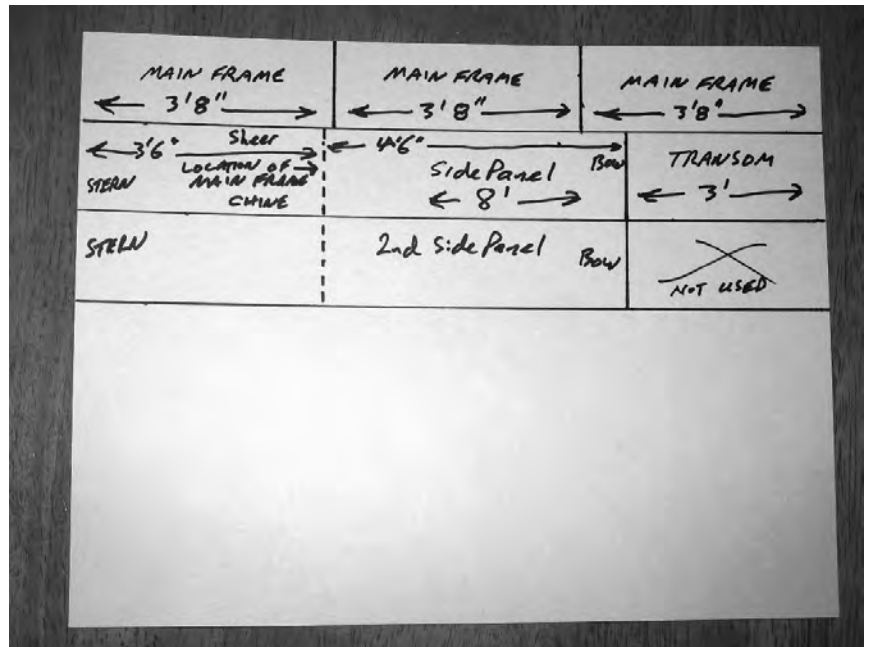

The next step is to measure, draw, and cut out a main frame. Main frames on small flat bottomed skiffs and dinghies help to define the hull shape. Plain Jane will have an overall length of less than eight feet, and the hull shape for this design is quite simple, so only one main frame is required. Also note Plain Jane has plumb sides (no flare), such that the beam (width) at the main frame location is the same at the sheer and at the chine. This means the main frame only requires another simple rectangle.

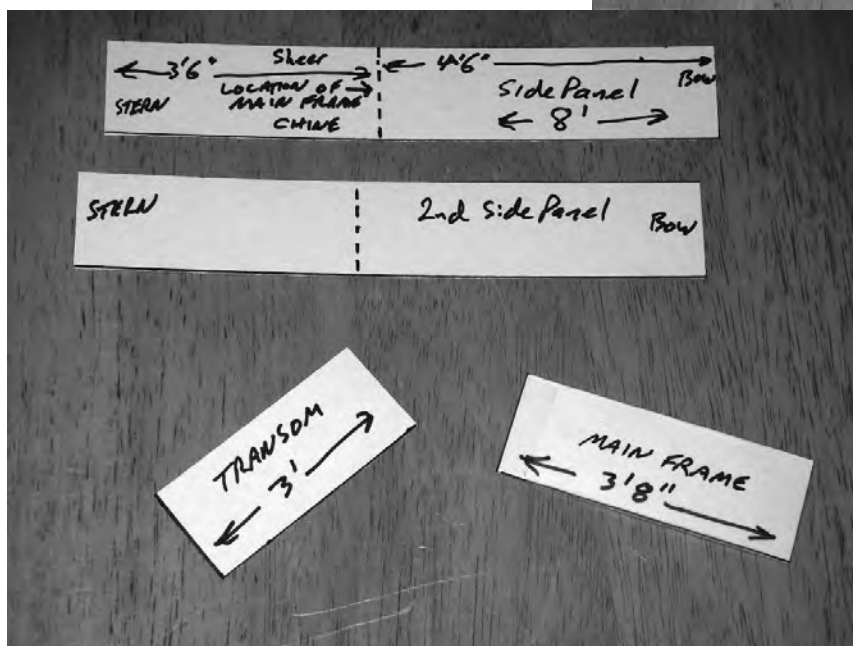
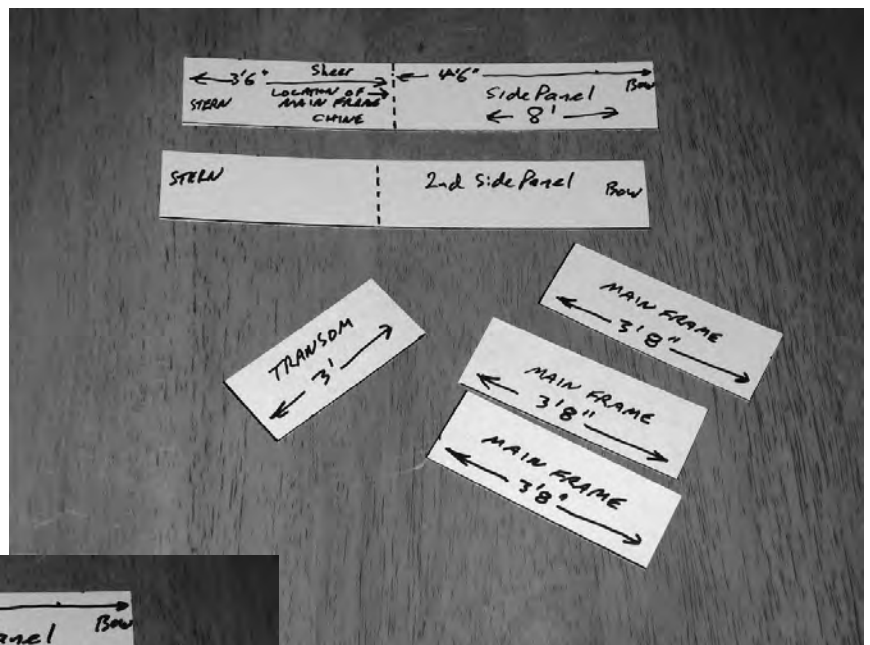

For this exercise, a rectangle measuring 3'8" across and 1'4" high will be sufficient. You should make at least two, and possibly three of these. Then tape or glue them together so the main frame will have greater stiffness than the other hull components. This is required in order for the main frame to properly define the hull shape in the hull model.

The transom (the "back" or stern of the boat) is another rectangle. Once again, there is no rake aft at the stern, nor is there any flare of the side panels for this basic design. You will

have to measure, draw, and cut out a rectangle measuring 3' across and 1' 4" high. Only one is required. There is no need to double up the transom panel for your model.

Assembling Plain Jane

Assembling your card stock scale model of Plain Jane follows similar steps building the full size boat, with the exception of all the missing structural components found in the larger craft. After the hull model is complete, some measurements can be lifted from the hull and used to calculate hull displacement, buoyancy, and so forth.

Begin by placing the two side panels together in perfect alignment, with the main frame location lines facing inboard (the inside of the boat). Place a piece of cellophane tape over the two panels at the end marked "bow." You can now spread the panels open into a "V" shape.

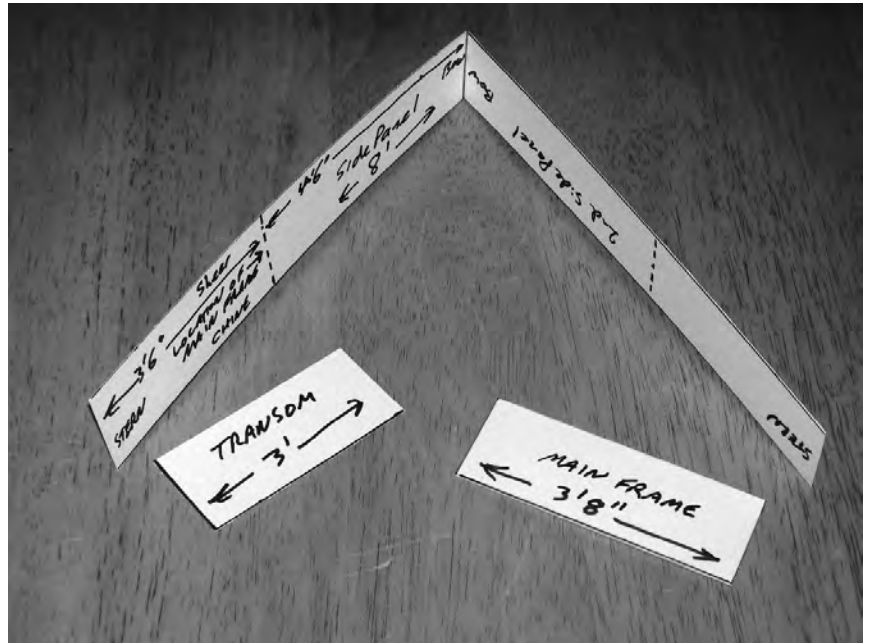

Align an edge of one end of the main frame with one of the lines marked "main frame location" on the inside face of a side panel. Use cellophane tape to make this construction joint with tape on both sides of the main frame panel onto the inside face of the side panel. Repeat this same step on the opposite end of the main frame, securing it to the inside face of the other side panel. You should now have a shape that looks very much like the letter "A."

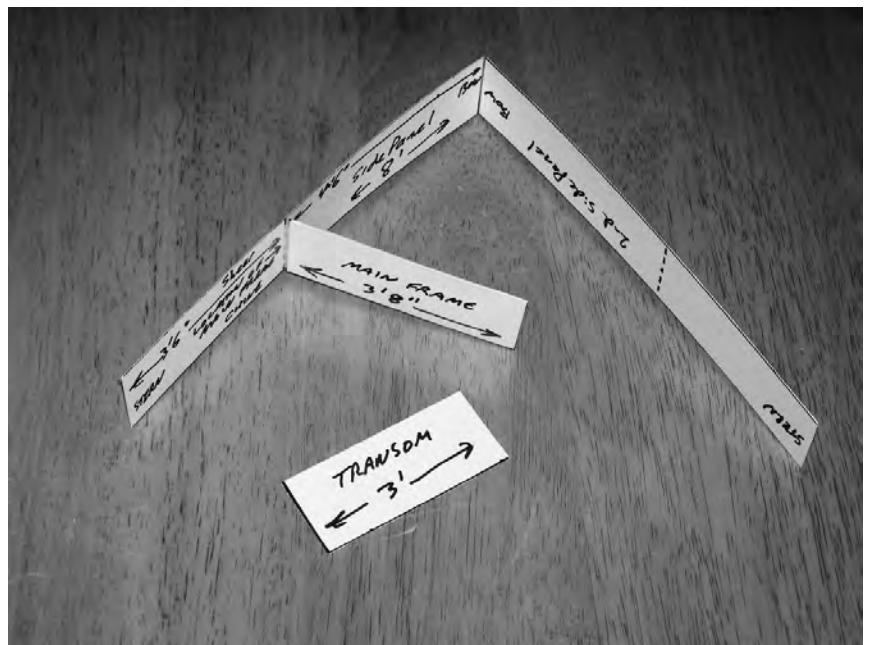

Align the edge of one end of the transom with the edge at the stern end of one side panel, and join with cellophane tape. Repeat the process for the other end of the transom and the edge of the other side panel. Your model is now complete for the purpose of observing the hull shape in 3D. It should have a typical boat shape from the top view.

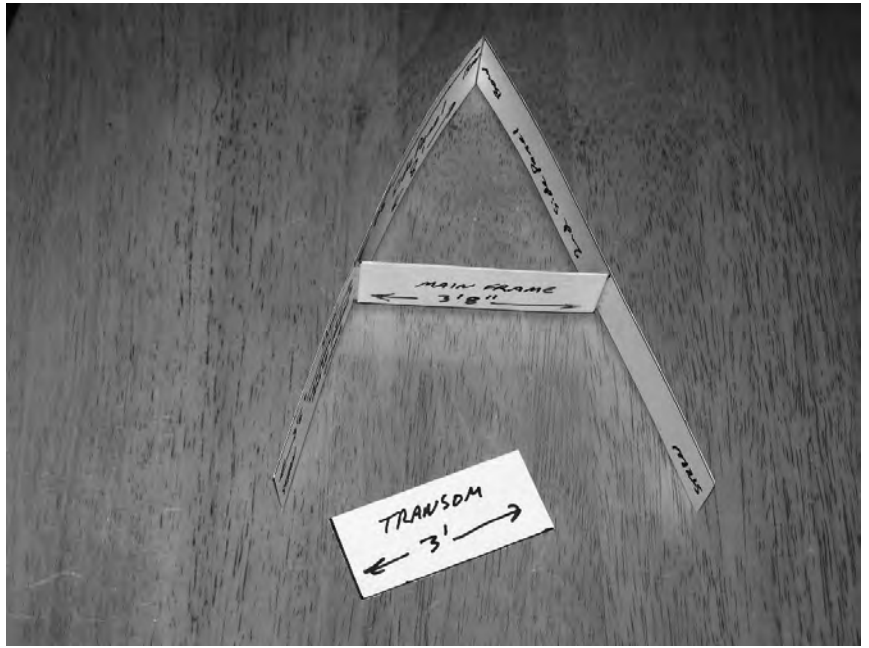

You can now understand why I chose to call this initial design Plain Jane. It would not be practical to build this boat full size. The performance would be very poor, and the hull would be structurally inferior to a similar hull featuring just a few minor changes, allowing the hull panels to be “stressed” with a bit of curvature adding greater hull rigidity.

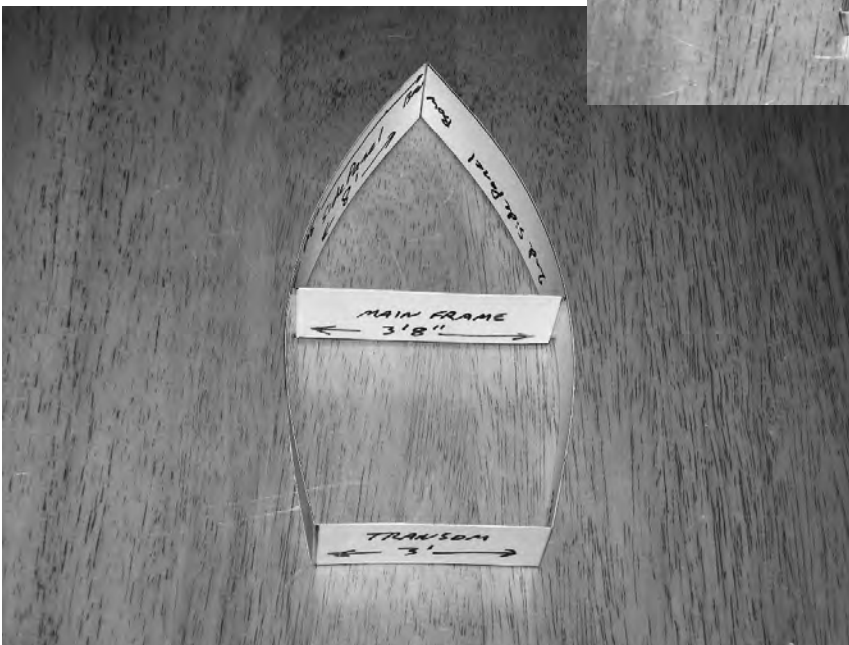
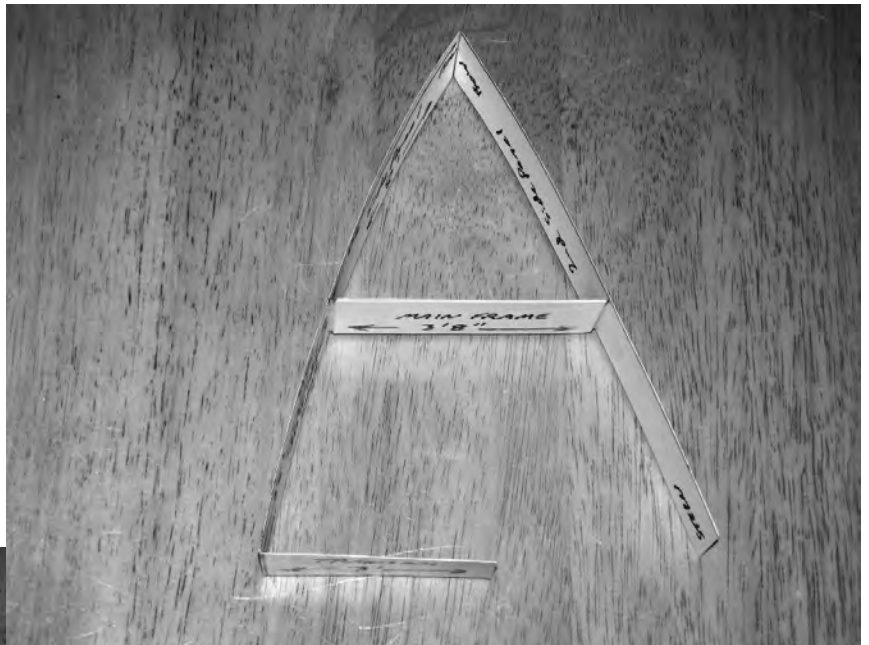

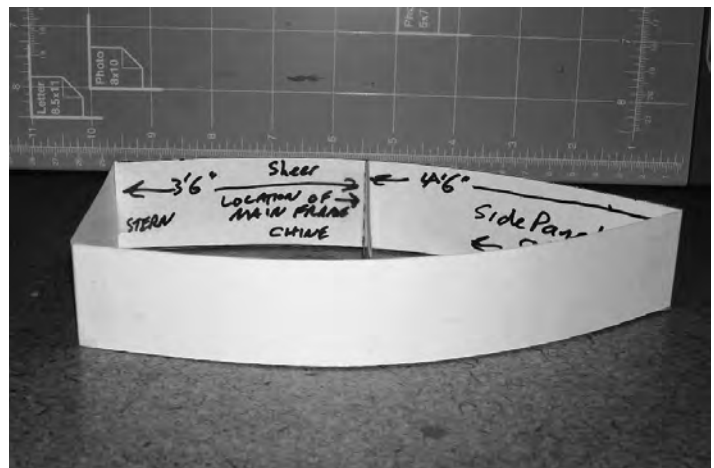
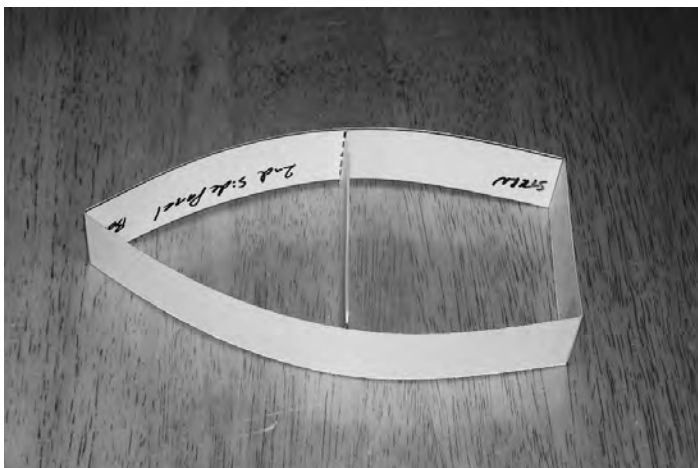
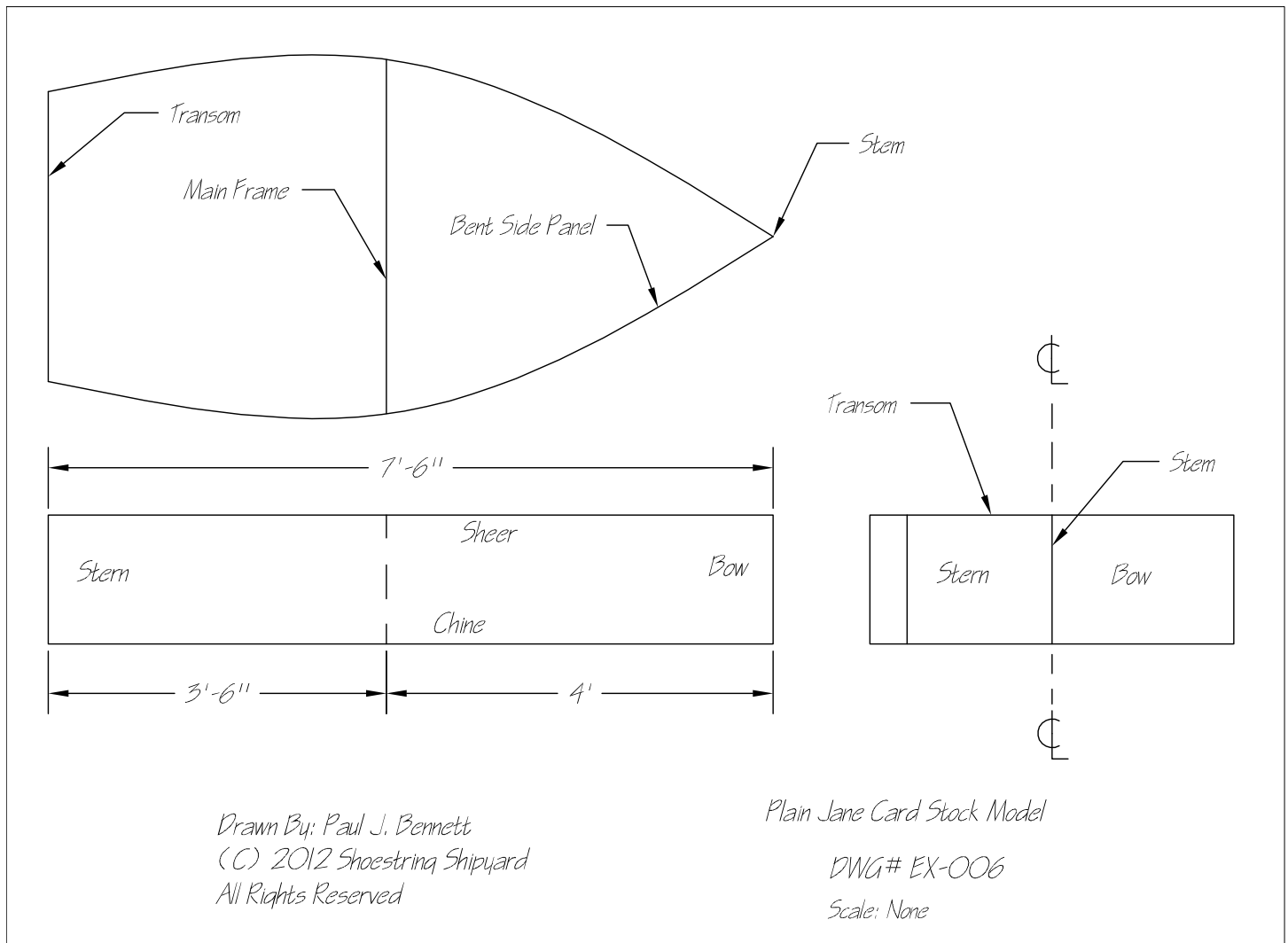

Plain Jane Hull Calculations

Place the Plain Jane card stock model on a table with a flat surface. Using the architect's scale, certain measurements can be obtained. This is called "taking off measurements" and normally refers to actual measurements taken from a full sized boat. You don't have one of those yet, so your card stock model will suffice for the time being. Measure the

overall length of the model at the centerline between the bow and the transom. If you measured and cut all of your panels accurately, and properly assembled them, you should read 7' 6" from the scale.

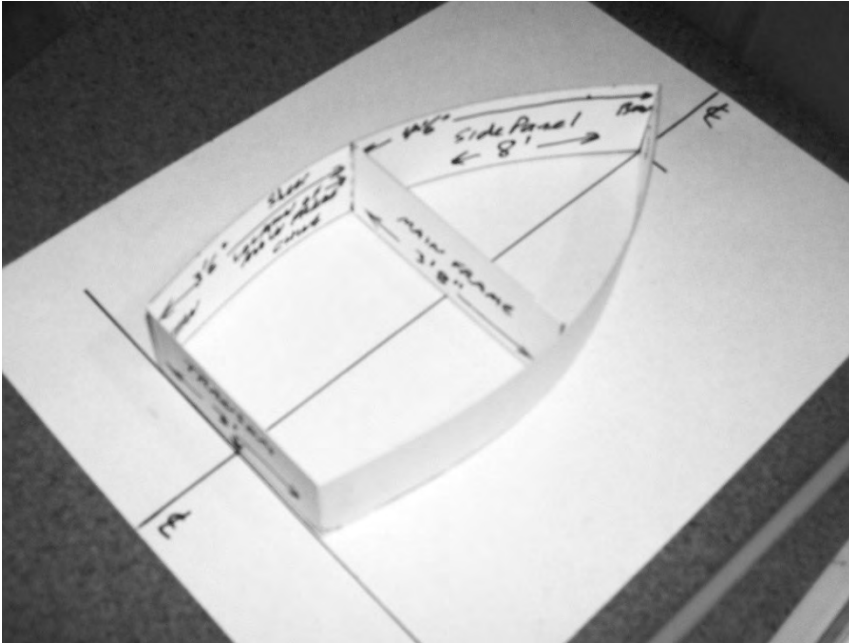

Use pencil so you can erase any mistakes during this next exercise. Draw a straight, horizontal line across a piece of paper. Make two marks along the line that are 7' 6" apart, using your architect's scale. Mark the center of the transom on the card stock model at the bottom of the transom panel. Place the model on the paper, over the line you just drew, and align the bow and the centerline mark on the transom with line and between the two marks along the line.

If you are very careful, you might be able to trace a line around each side panel from bow to stern on the paper under the boat model. Otherwise, you can make a few marks along the base of the boat around the panels on the paper. You can then draw in the curve of the side panels with a French Curve, or flexible batten, using the marks as a guide. All that is left is to draw a perpendicular line to the horizontal line drawn earlier, at the stern end and between the side panel marks.

The horizontal line originally drawn is the centerline of the boat. You can now scale and take off other measurements; however you can do so from the new drawing which is much easier to do.

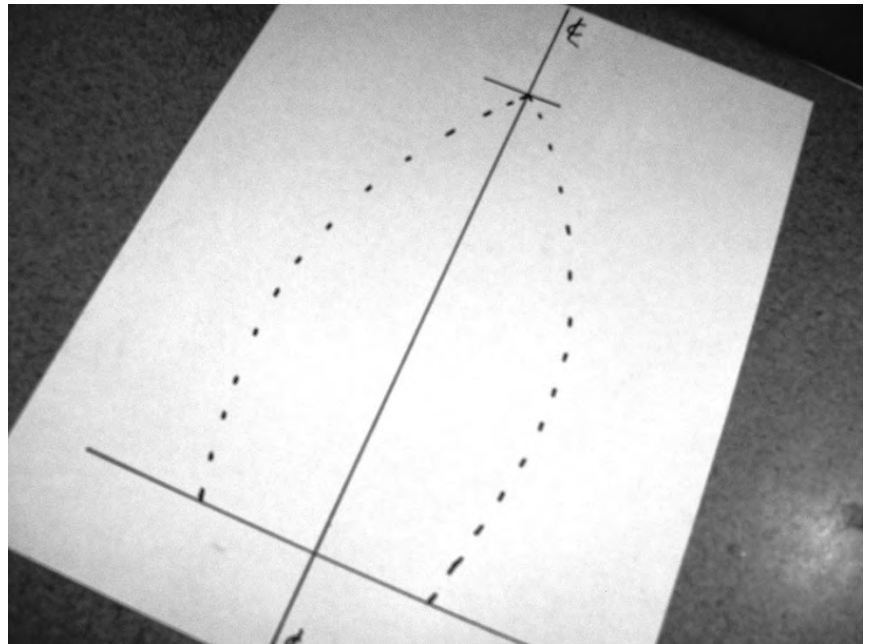

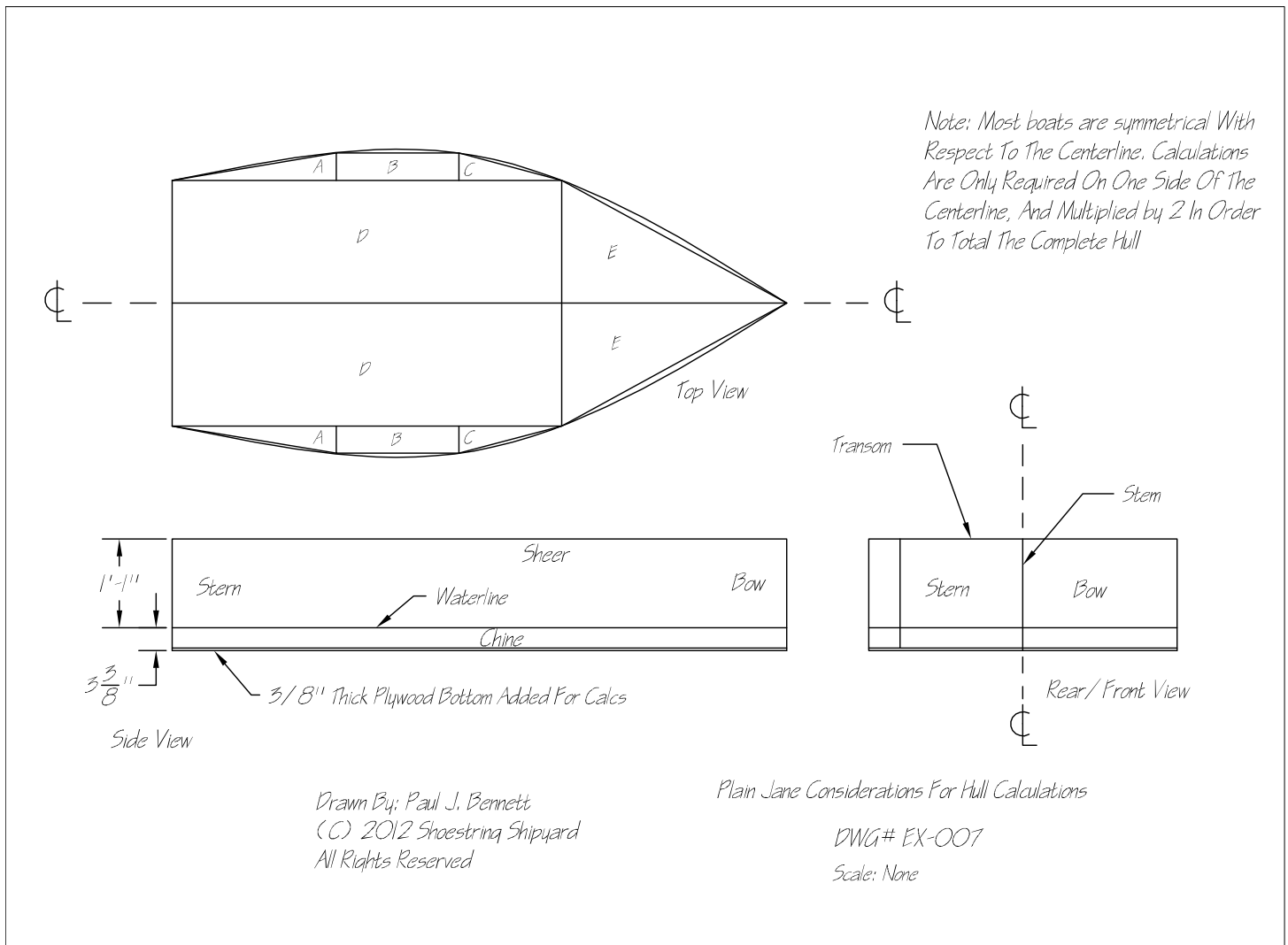

Your drawing should look something like the top view in illustration DWG# EX-006. Now draw in a series of horizontal and vertical lines within the hull shape as shown in illustration DWG# EX-007. You will note the lines form a series of rectangles and right triangles. When measured with your architect's scale, you should read (or at least close) the same measurements shown in illustration DWG# EX-008.

Note I only drew half of the hull shape on one side of the centerline in my example. This is because most boat hulls are designed to be symmetrical, so only one side requires measurements and calculations. When you have your total, simple double it to get the area for the bottom panel or volume for the entire

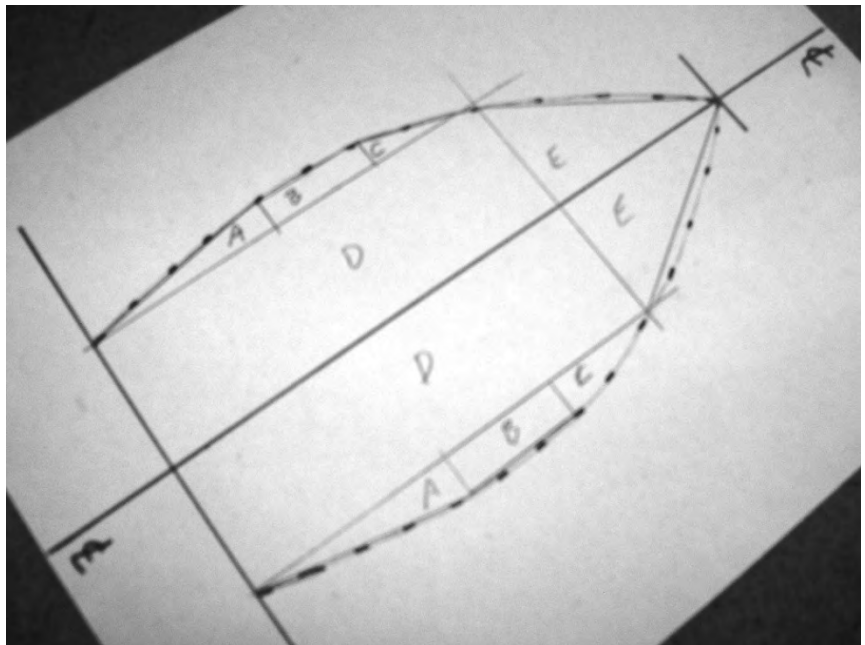

hull. The whole vessel can be calculated if you want, however this method simply eliminates a lot of time you might spend otherwise. The illustration shows a list of calculations for each shape, all lettered in order to better keep track of them, and also displays the total area of the bottom panel.

DWG# EX-008

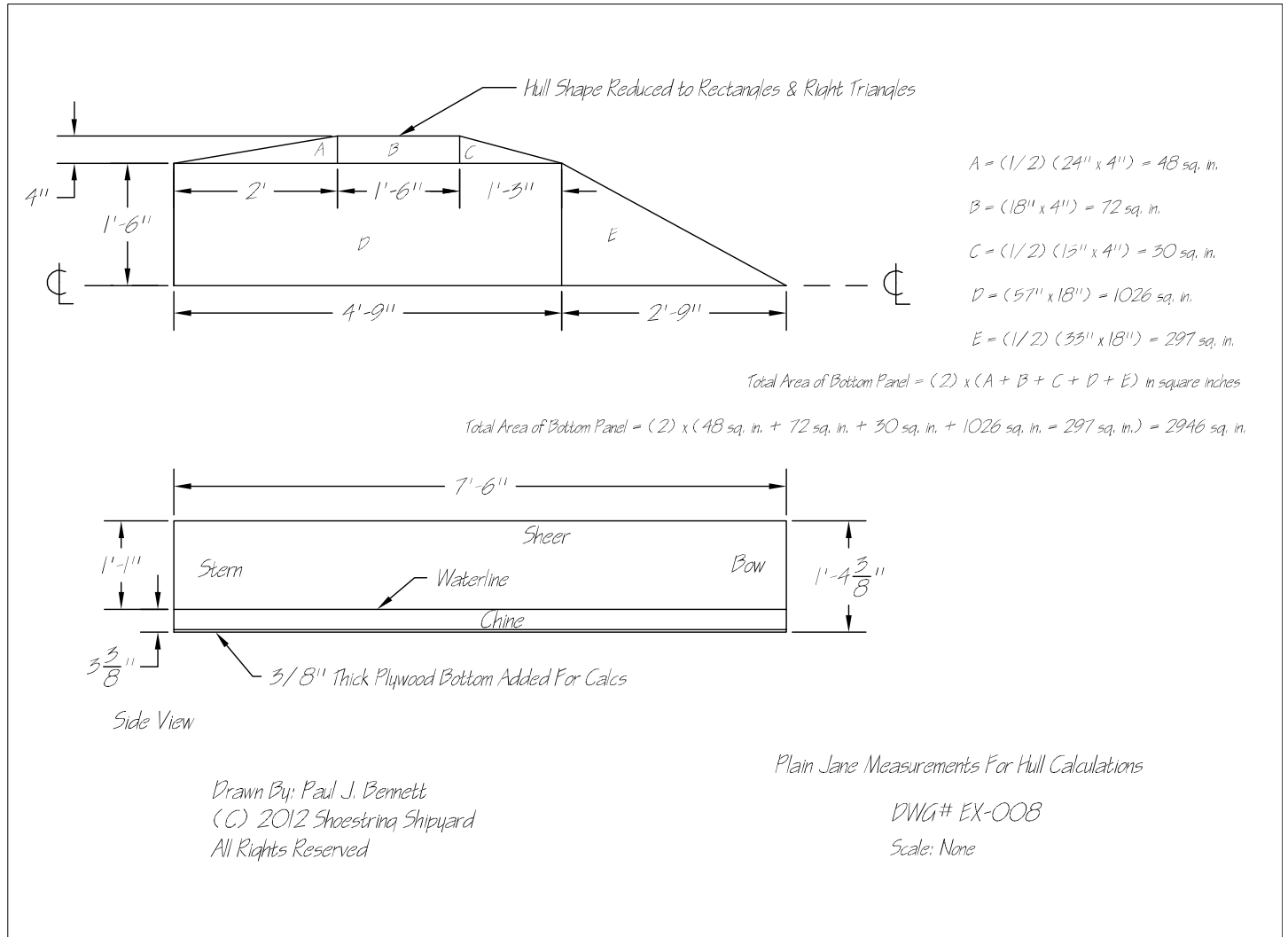

To assure no one is left behind, I simply wish to remind everyone the area of a right triangle is found by multiplying the base times the height and then multiplying times $\frac{1}{2}$ (or dividing by 2). Finding the area of a rectangle is accomplished simply by multiplying the base times the height. When the areas for all of the shapes represented in the drawing are found, you simply add them up for the total area of one half the bottom panel. Doubling that figure (multiplying by 2) will give you the total area for the entire bottom panel.

You can elect to make your calculations in feet, inches, or other units of linear measurement. I chose to use inches in my example, so my answer is in square inches. Note the drawing in my illustration shows both feet and inches. This is common with many boat designs and architectural drawings. You must convert the feet to inches or the inches to feet in order to make accurate calculations.

Many readers are sure to note the hull sides are curved and small areas outside the right triangles and rectangles (but inside the curves) were not accounted for in my calculations. Great catch if you did happen to notice it. You will also note the areas neglected are very small, and unlikely to make much of a difference in my totals. These neglected areas can be accounted for if you desire a higher degree of precision. This is accomplished by drawing to a much larger

scale so it's easier to measure. Given all of the variables and assumptions used in my calculations, the smaller areas not calculated for Plain Jane are relatively insignificant.

Plain Jane Math

The first consideration is; how much does Plain Jane weigh dry (out of the water without hardware, people, or gear)? We can find out by taking inventory of all the components making up the basic hull, and adding up all of their individual weights. In order to accomplish this, the density/weight of the material used must be known as is the total volume of each component. The weight of each component can then be calculated very much the same way as was shown earlier in the "cube boat" example. The Plain Jane example is slightly more complicated because it requires plywood of various thicknesses, requiring more calculations.

Given information for determining weight of Plain Jane:

- Fir plywood weighs 37-1/2 pounds per cubic foot
- There are 1728 cubic inches in one cubic foot
- Plain Jane (for this example) is all plywood
- There are (2) Side Panels, both measuring 16" x 8' x 1/4"
- There is (1) Transom measuring 16" x 3' x 3/4"
- There is one Main Frame measuring 16" x 3'8" x 3/4"
- There is one bottom panel cut from 3/8" ply with an area of 2946 sq. in.
- Add 15 pounds to allow for epoxy, fasteners, glass tape & paint

Begin by converting all measurements to the same units. This is important to avoid miscalculations.

(2) Side Panels = 16" x 96" x 1/4" each

Volume of Side Panels = (2) (16" x 96" x .25")

(Note I converted the 1/4" measurement from a fraction to decimal in order to make it easier to solve the equation with a calculator)

Volume of Side Panels = (2) (1536 sq. in. x .25") = (2) (384 cu. in.) = 768 cu. in.

Volume of Transom = 16" x 36" x 3/4" = 576 sq. in. x .75" = 432 cu. in.

Volume of Main Frame (assuming 3/4" plywood for this example) = 16"x42"x.75"

Volume of Main Frame = 672 sq. in. x .75" = 504 cu. in.

Volume of Bottom Panel = 2946 sq. in. x .375" = 1104.75 cu. in.

Volume of plywood hull in cu. in. = 768 + 432 + 504 + 1104.75 = 2808.75 cu. in.

Volume of plywood hull, rounding off to nearest whole number = 2809 cu. in.

We know there are 1728 cubic inches in one cubic foot, so to convert the hull volume to cubic feet, divide 2809 cu. in by 1728 cu. in. Thus:

2809 cu. in. / 1728 cu. in = 1.63 cu. ft. (rounded off)

We know the weight or density of the fir plywood is 37- ½ or 37.5 pounds per cubic foot. To find the total weight of the plywood used to build Plain Jane, multiply 1.63 cu. ft by 37.5 pounds, thus:

$$1.63 \text{ cu. ft.} \times 37.5 \text{ \#/cu. ft.} = 61.125 \text{ pounds}$$

You can call the total weight of the plywood portion of the hull 61- 1/8th pounds or simply round off and call it 61 pounds.

Remember to add the 15 pounds of other materials estimated to the plywood hull weight.

$$61\# + 15\# = 76 \text{ pounds Total Hull Weight.}$$

This is actually a very realistic, ball park weight for a small dinghy of this size. They do vary significantly, depending on how they are outfitted, types of materials chosen, and a number of other variables.

Now that we know the total dry weight of the hull, it is time to calculate total hull volume, hull volume at the chosen waterline, and pounds of flotation (buoyancy).

It will be quite easy to make these calculations for Plain Jane because this design has a plumb (plumb, meaning vertical – straight up and down – no angles) stem, plumb transom, plumb sides, and no rake, rocker, or flare in the hull.

The area of the bottom panel is 2946 square inches. Looking at Illustration DWG# EX-007, note the total distance from the bottom of the boat to the top (sheer) measures 16-3/8” or 16.375” and simply multiplying the height of the hull by the area of the bottom will give you the total volume of the hull in cubic inches.

$$\text{Total Volume of Hull} = 16.375'' \times 2946 \text{ sq. in.} = 48241 \text{ cu. in.}$$

To find the total volume in cubic feet, divide 48241 cu. in. by 1728 cu. in. per cu. ft.

$$\text{Total Hull Volume in cubic feet} = 48241 \text{ cu. in.} / 1728 \text{ cu. in. per cu. ft.} = 27.86 \text{ cu. ft.}$$

Since we know the density of seawater to be about 64 pounds per cubic foot, and we now know the total hull volume to be 27.86 cubic feet, we can calculate

The total weight of the seawater the hull will displace if it were to be submerged right to the top rail of the boat (sheer line).

$$\text{Simple multiply } 64\# / \text{cu. ft.} \times 27.86 \text{ cu. ft.} = 1783 \text{ pounds (weight of total hull displacement)}$$

We chose an arbitrary waterline measuring 3-3/8” or 3.375” up from the bottom of the boat. To find the volume of water displaced if the dinghy is submerged to this point, multiply the bottom panel area of 2946 square inches by the height of 3.375” for the volume displaced in cubic inches.

$$3.375'' \times 2946 \text{ square inches} = 9943 \text{ cubic inches}$$

Once again, we need the volume in cubic feet so we convert by dividing 9943 cubic inches by 1728 cubic inches per cubic foot.

$$9943 \text{ cu. in.} / 1728 \text{ cu. in. per cu. ft.} = 5.75 \text{ cubic feet (waterline displacement)}$$

Total weight of seawater displaced by the hull at the waterline is 64# / cu. ft multiplied by 5.75 cubic feet.

64# / cu. ft. x 5.75 cu. ft. = 368 pounds (weight of hull displacement to waterline)

If 368 pounds is divided by 3.375 inches, we will know how much weight can be added to immerse the dinghy an inch further down in the water (this raises the waterline one inch and decreases freeboard by one inch. This is called pounds per inch, immersion. Freeboard is the distance from the lowest height from the waterline to the sheer line (all the same on the Plain Jane design).

Pounds per inch, immersion = $368\# / 3.375'' = 109$ pounds (it takes 109 pounds to lower the boat 1 inch in the water)

Summation of information we have solved for in order to make further calculations and determinations:

- Total dry hull weight = 76 pounds
- Total hull displacement in seawater 27.86 cu. ft and 1783 pounds
- Displacement in seawater at waterline 5.75 cu. ft and 368 pounds
- Pounds per inch immersion = 109 pounds
- Freeboard at arbitrary waterline = 13''
- Buoyancy – Weight of total hull displacement minus total hull weight = 1783 pounds – 76 pounds = 1707 pounds
- Payload at arbitrary waterline = 368 pounds – 76 pounds = 292 pounds

This means you can load the dinghy with people and gear up to 292 pounds, and the dinghy will float at the arbitrary waterline given in the initial design. Dinghies of this size do not hold very much in load capacity (safely), but only 292 pounds is just not enough for two average sized adults and their gear.

I like to maintain at least 12'' of freeboard whenever possible to reduce slop from waves and chop from entering the boat when it starts to blow a bit. Less freeboard will work in calm, sheltered harbors, but I've seen small dinghies dangerously overloaded all too often.

Note the freeboard is 13'' using the arbitrary waterline. Also note the pounds per inch, immersion is 109 pounds. If I raise the waterline by one inch (lowering the freeboard by 1''), I can add 109 pounds to the 292 pounds of payload capacity for a safe load total of 401 pounds. The freeboard is now at 12'' and 401 pounds is ample for a dinghy of this size.

I would now draw the plans such that the boat will have a waterline measured at 4-3/8'' up from the bottom. I would then specify a maximum load capacity of 400 pounds for persons, motor, and gear.

Reserve Buoyancy: The total hull displacement in the density of seawater is 1783 pounds. The total weight of the hull (76 pounds) plus the maximum load capacity (400 pounds) = 476 pounds. The reserve buoyancy is 1783 pounds – 476 pounds which equals 1307 pounds. This allows for a safety factor over 2.5 which is not bad at all.

Other considerations: The USCG requires positive floatation material that will allow the gunwales to float just above the water surface if the boat is completely swamped, such that it can be bailed out by the crew (if you are building and selling boats as a commercial enterprise). The hull is made with plywood and we know the plywood has positive buoyancy. We don't know what the buoyancy is (positive, neutral, negative) of the persons, motor, and gear.

If we divide the maximum load capacity of 400 pounds by the density of seawater (64 pounds per square inch), we

will have the volume of flotation material needed in cubic feet. In this case, 400# divided by 64# per cu. ft. = 6.25 cu. feet of flotation material required. The flotation material (lightweight, closed cell foam) can be installed under the thwarts (seats) – see drawing # DD-8 found within this guide.

In this Plain Jane example, dimensional lumber used for thwarts, frames, breasthook, quarter knees, and transom knees; skeg, keel, and a host of other things were not considered or added to the calculations. This was done purposefully in order to simplify the process, and not bog you down with too much just yet.

The Plain Jane exercise is a good start, enabling you to grasp a few basics, and then move on to a more complex example; building upon what you have just learned.

The Simple Simon Design Exercise

In this example, you'll see how Simple Simon was developed from Plain Jane, and you'll understand how you can do something similar to design your own dinghy. The simple method used for Plain Jane for making hull calculations is more difficult and less accurate to use with Simple Simon, because Simple Simon has a more complex hull shape. The stem and transom feature a few degrees of rake, the bottom has rocker fore and aft, and the side panels have flare.

This is where using calculus and ordinary differential equations to find hull displacement makes sense, as it is the fastest, and perhaps most accurate way to determine the answers you are seeking. The next method involves using solid geometry with analytical trigonometry and advanced algebra. This takes longer, perhaps a little less accurate, but worthy of consideration. Lastly, we can find the volume of rectangular and triangular shapes in much the same manner as used in Plain Jane, but by taking measurements athwartships (across the hull) in vertical sections just a few inches thick each, instead of the horizontal sections measured in the Plain Jane exercise. I'm not going to offer a detailed exercise as was given for Plain Jane. I simply wished to point out how more complex shapes require more extensive and complex math calculations.

One more note; I have altered the figures used in the Simple Simon example from the ones employed in the actual Simple Simon design, just making the example easier to follow. If you decide to build the Simple Simon 8' design from the plans contained in the book, I want you to know the specifications are much different than what you will find in this exercise.

Looking at illustration DWG# EX-009, you might notice all of the boat hull panels for Simple Simon have the same dimensions in overall length and height as those used for Plain Jane (illustration DWG# EX-005). There is a big difference though. Notice there are triangular sections cut off at the ends. Making simple alterations to panels the with the exact same over dimensions as Plain Jane will significantly alter the looks, characteristics, displacement, overall dimensions, and performance of the boat.

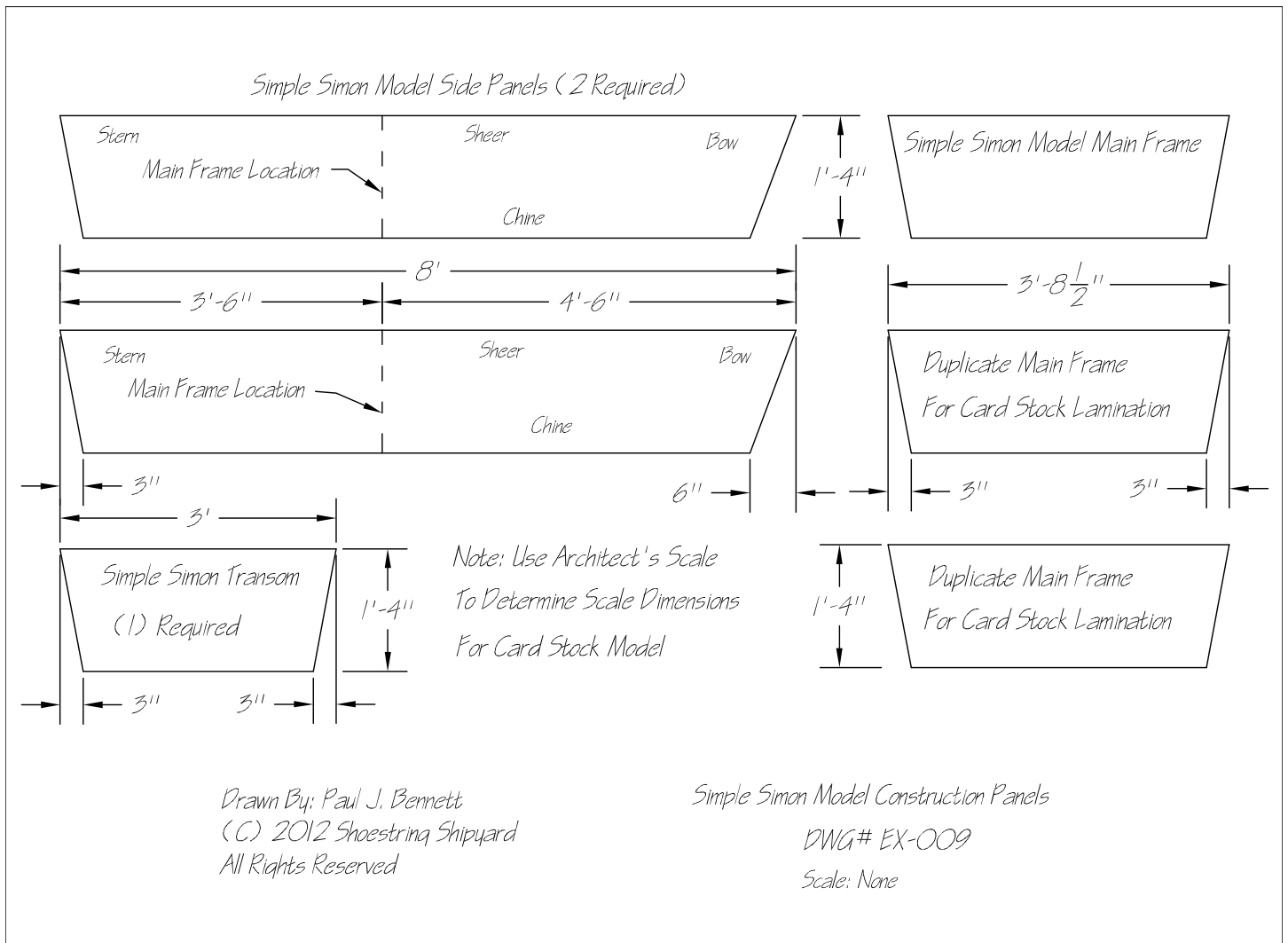

Draw the panels shown in illustration DWG# EX-009 in 1/12th scale on a sheet of card stock as you did for Plain Jane. Make sure you label the panels and mark the main frame location on the side panels. Cut out the pieces and assemble them in the same order and fashion as you did while constructing the Plain Jane model.

DWG# EX-010

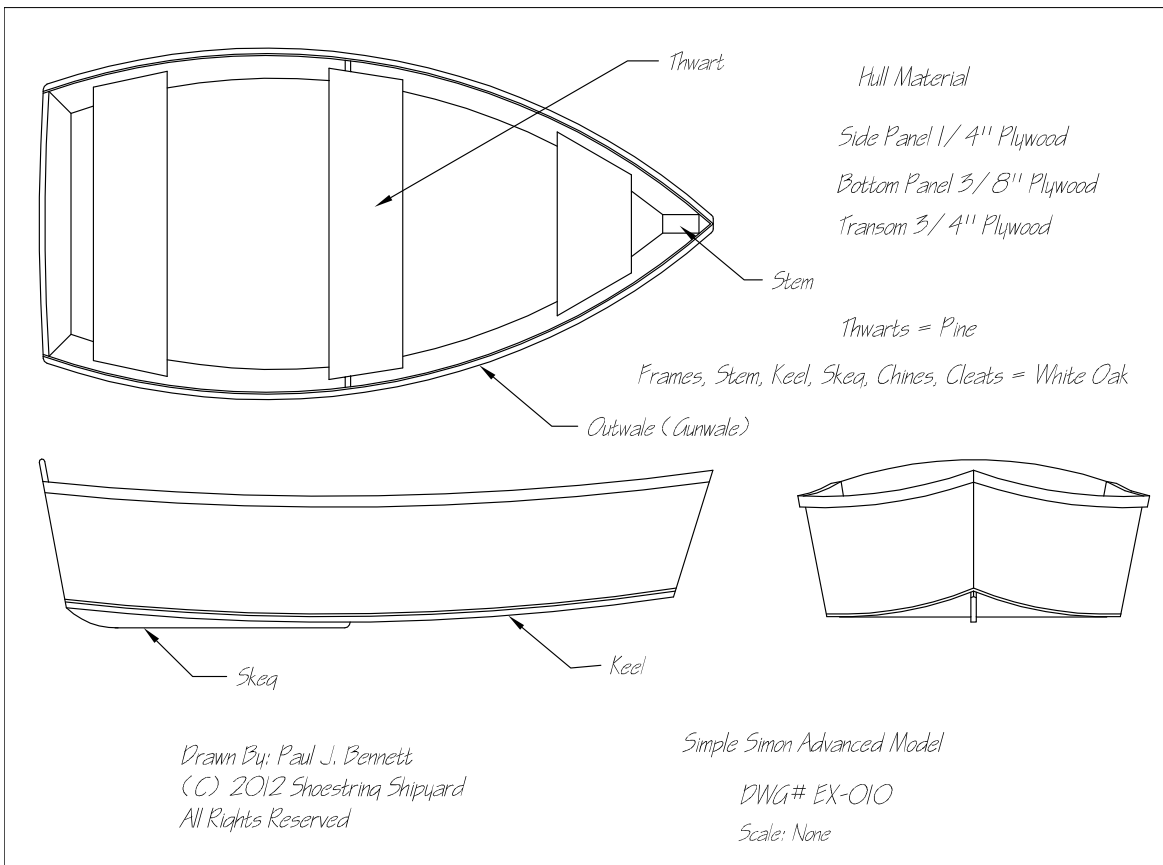

DWG# EX-011

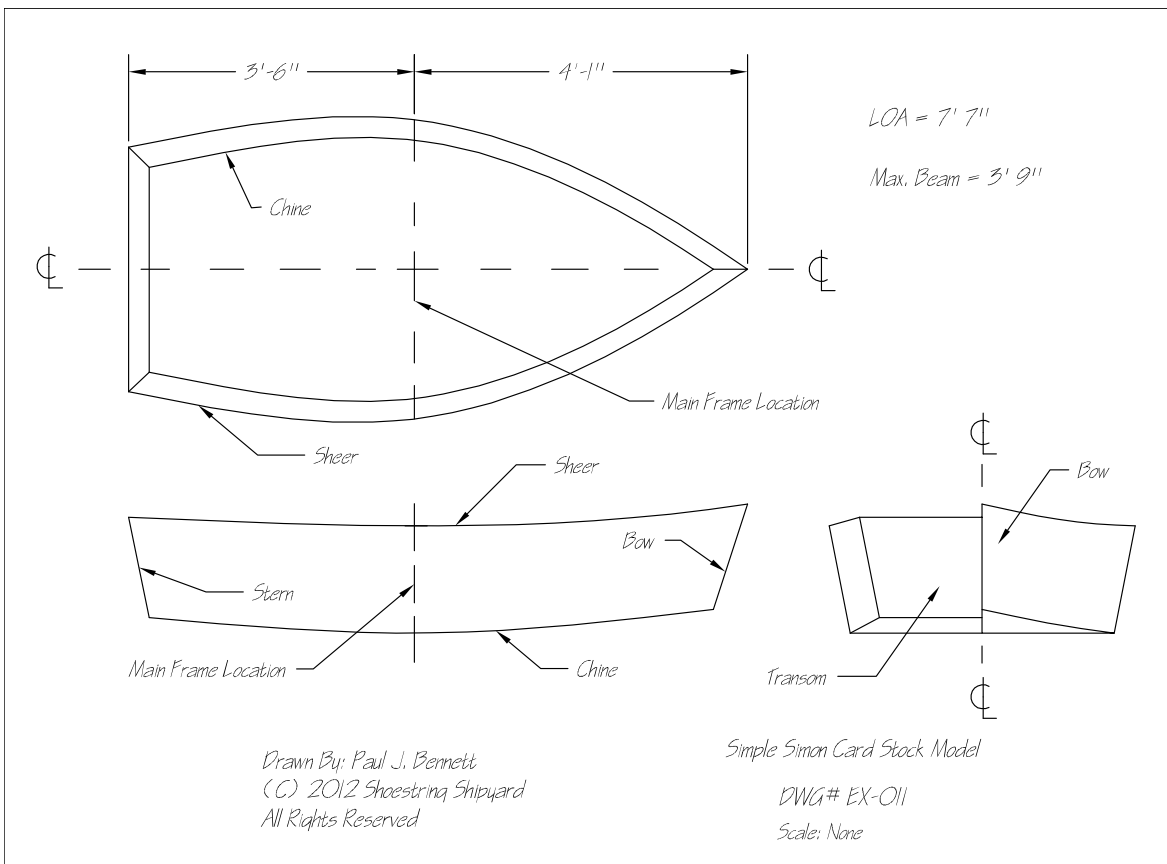

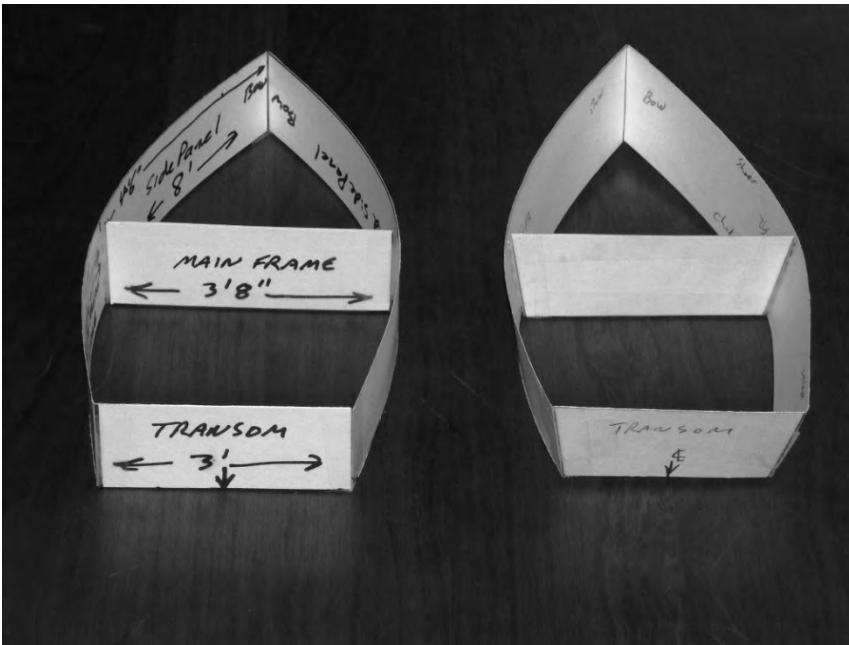

Your Simple Simon model will look like a completely different boat design when you are finished. Sit it alongside the Plain Jane model and compare them together. You can make other models by altering the shape of the side panels, transom, and main frame; making them your own design. Just one thing to keep in mind is not to cut your side panels any longer than 8' because this is the longest dimension you can use with a standard size sheet of plywood. Don't make the maximum beam (width) of the hull more than 4' at the chine for the same reason; the maximum width of a standard size sheet of plywood is 4'.

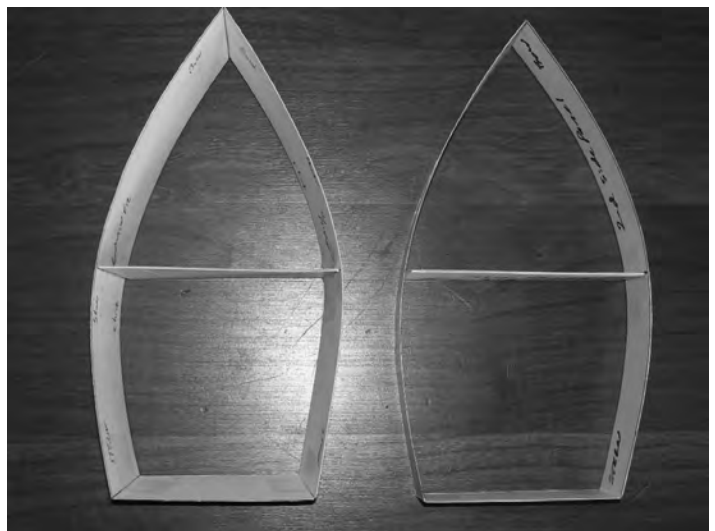
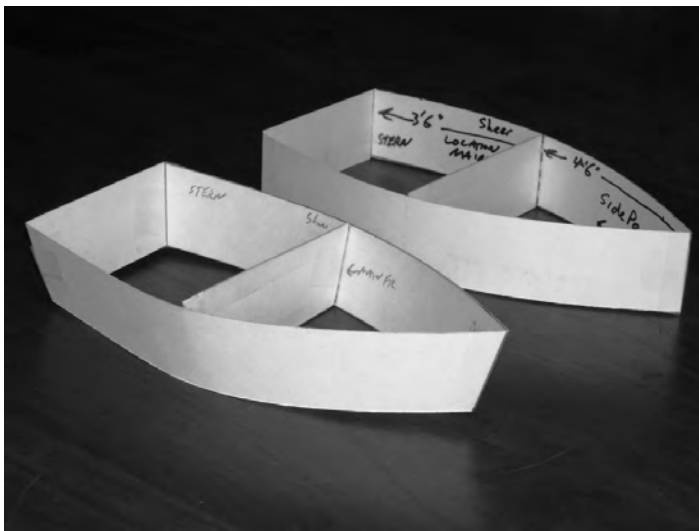

It's Your Turn

Take another sheet of card stock, layout another set of panels, but use whatever dimensions or curves in the panels you wish. Cut the panels out, and assemble them much like you did with Plain Jane and Simple Simon. How does it look? Is it pleasing to your eye? Do the lines flow?

If your own design has merit, you can take off the measurements using a scrap piece of card stock, a pair of dividers, and your architect's scale. You can then transfer the measurements to a piece of paper and make a scaled drawing.

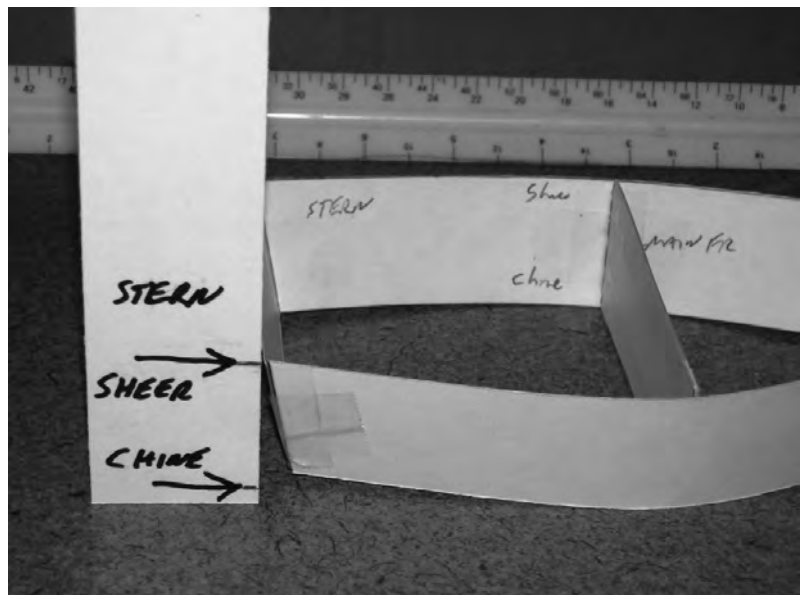

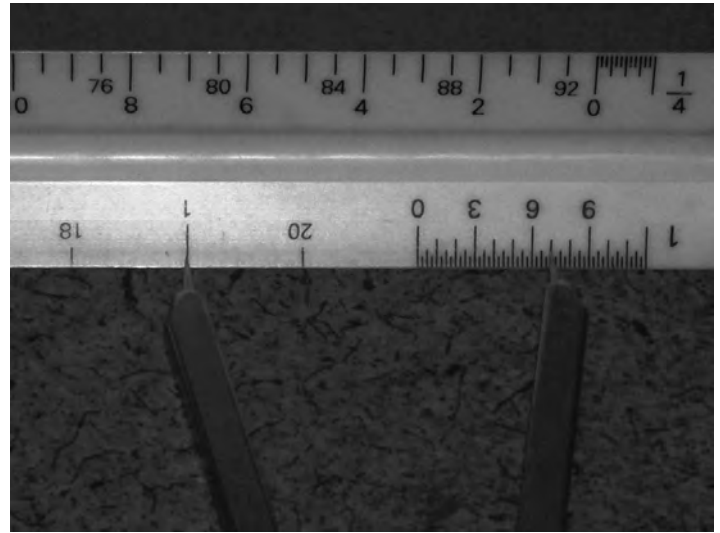
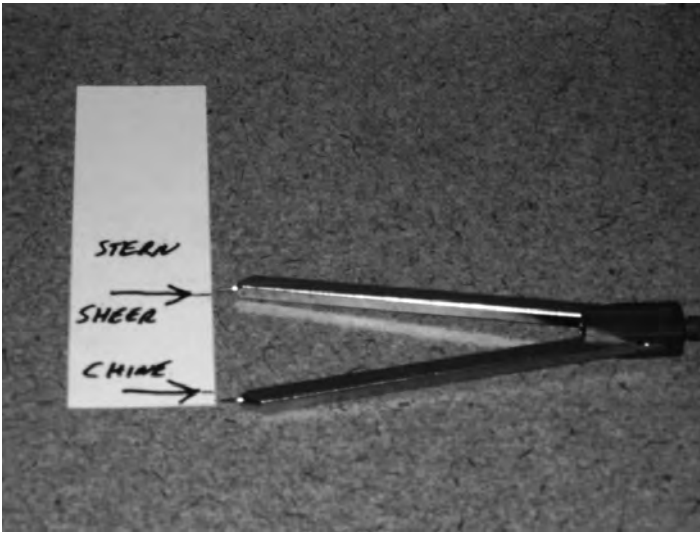

Build a Large Scale Model

Once you have settled on a hull shape you like, have drawn scaled plans; and have completed the calculations for buoyancy and hull weight, it's a good idea to build a large scale (1/4th scale or 3"=1') model using very thin plywood or basswood and Am-broid™ fast drying wood model cement. It's not absolutely necessary to build a large scale model, however doing so will help you understand how the full sized boat will be assembled. The following photo is a 1/4 scale model I built years ago of Simple Simon.

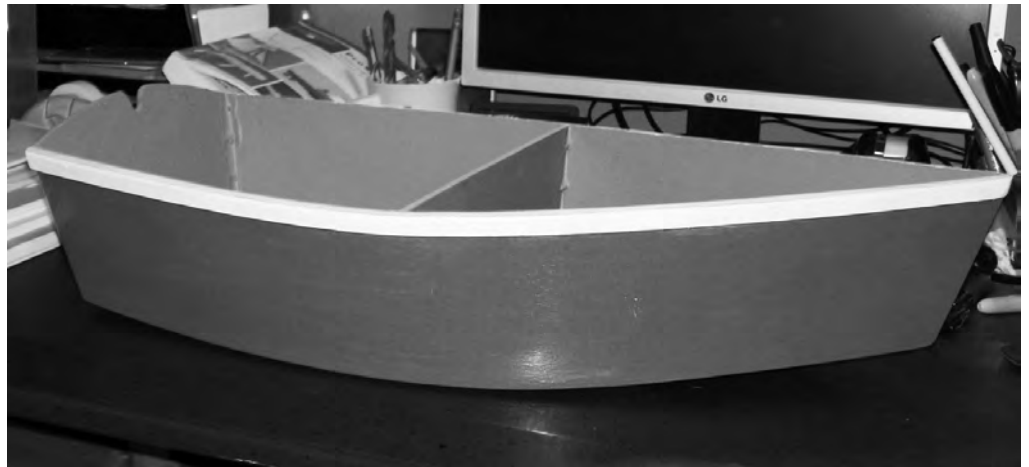

Simple Simon 8'

Simple Simon is a 7'7" dinghy I designed specifically for use in teaching basic boat building courses. It's perhaps the easiest boat to build that I've ever designed, and should prove popular for classes of short duration, or consisting of young students. Builders of this tiny ship will find the cost of materials quite agreeable, and the vessel rugged and seaworthy.

Simple Simon is constructed with exterior plywood, a couple of common KD building studs, a few stainless steel screws, 3" wide fiberglass tape, and some epoxy resin. A small amount of primer, paint, and a little hardware will finish off the project. Personal Flotation Devices and a pair of oars are the only additional accessories the prospective builder will have to procure to make the boat ready for its initial launching.

The two most common methods of plywood boat construction used by backyard boat builders are popularly known as "Glue-N-Screw" and "Stitch-N-Glue". Simple Simon is a hybrid design employing both of these construction techniques so one course covers two building methods. Instructors and more experienced home boat builders can certainly build Simple Simon using either construction technique by itself rather than the combination of two methods if desired.

The design of Simple Simon fits into a lesson plan consisting of eight classes, each of three hours duration. Sufficient time was allowed for setup of workspace and clean up following each lesson. It's possible to develop a two-day, intensive training class for building this boat if preferred (I personally built the prototype of the basic hull in about eight man-hours).

There are a few prerequisites for students wishing to participate in classes offered for building Simple Simon: The prospective student should have rudimentary wood working skills used in basic/rough carpentry. He or she must be familiar and experienced with operating the basic hand and/or power tools necessary for building the boat in class. The student should understand this course focuses on basic boat building, and may not offer instruction in the use of tools or basic carpentry skills.



This manual may be offered as a text for use in formal boat building classes; however it is possible for experienced wood workers to use it as a step-by-step guide to build Simple Simon at home without the benefit of a classroom environment. The various construction steps are broken down into easy to follow segments, along with photographs and drawings. If opting to build Simple Simon using the Stitch-N-Glue method either partially or completely, you will find a couple of illustrations in the detail drawing section of this book, depicting common Stitch-N-Glue practice.

Row it, tow it, or sail it with a simple sprit rig. Simple Simon 8 will prove to be a fun project that takes little time, and provides a useful, utilitarian dinghy that can be used as a tender, or for recreation. The important thing to remember is to have fun and enjoy the boat building experience. You can build this boat on the cheap for a “quick & dirty” workhorse, or you can dedicate this boat as a shrine and build it to the most exacting yacht standards. Maybe somewhere in between is best for you. This is your boat, your money, your sweat, and your time. You'll have to make such decisions.

NOTE: When young people are allowed to participate in class, it is suggested that the boat be built using “Glue-N-Screw” building techniques. In such a situation; waterproof, urethane based glue might be used as an alternative in construction rather than epoxy resins (which contain carcinogens and can sensitize one's skin if there is contact with uncured material). The urethane-based glue is not as strong as the epoxy; however it's a safer alternative. Polyurethane based marine adhesives (such as 3M brand Formula-5200™) can also be used with the “Glue-N-Screw” construction technique (although very messy to work with).

If the “Glue-N-Screw” construction technique is chosen as a sole building method for Simple Simon 8 rather than the designed method in this manual, the builder will have to use many more stainless steel screws beyond the number specified. A fastening schedule for the “Glue-N-Screw” building method is included if the builder chooses this option. The following photo depicts details of a Simple Simon using a dimensional lumber main frame and traditional glue-n-screw chine construction:



Builders opting to build Simple Simon entirely using the “Stitch-N-Glue” method of construction may do so, using the main frame as a temporary mold and eliminating the stem. Such construction will of course increase the cost of construction, as more epoxy, glass tape, and filler materials will be required. I would also advise the builder to fabricate and install quarter knees and a breasthook at the very least if eliminating the main frame & stem.

Read through this book in its entirety and study the drawings, illustrations and photographs before beginning your building project. Go back over any sections you don't understand, and/or ask your instructor for help. If you are building Simple Simon at home and have difficulties, you may send an email to me with your questions: paul@shoestringshipyard.com or you may post your questions via “snail-mail” if you include a stamped, self-addressed business sized envelope. Technical questions will not be answered over the telephone. Please check out my blog at <http://www.shoestringshipyard.com/blog/> and read the section on frequently asked questions before emailing me.

After looking over the drawings, begin construction following the steps and instructions outlined earlier in the book. These are your guide throughout building Simple Simon.

If you choose the Stitch-N-Glue method for joining the bottom panel to the side panels, and eliminating the traditional chine log, the finished job might look like the Simple Simon in this photograph:

The photo shows the inside chine area that has been filleted with thickened epoxy, then had one layer of 4” wide fiberglass tape applied with non-thickened epoxy resin. The surface was sanded smooth to remove any rough edges and lumps. Then a mixture of epoxy resin and micro-balloons was applied over the glass tape and beyond the tapes edges to feather-edge the epoxy, essentially blending the joint to the hull with some final sanding. Note the main frame was cut from a solid piece of 3/4” plywood, and the wood cleat was fabricated from dimensional lumber (it supports the thwart which will be mounted later). As an option, the main frame may be fabricated using dimensional lumber.



Tools Needed To Build the Boat

The Bootstrap Dinghy can be built with a bare minimum of hand tools. However, it will take much longer, and require a great deal more effort than building with just a few additional power tools. A full shop of all the latest high-tech power tools such as Norm Abram's on "New Yankee Workshop" would certainly be ideal, but not likely for most of us.

Here's a list of the most very basic hand tools:

- crosscut saw
- rip saw
- keyhole saw
- block plane
- jack plane
- small, medium, large flat blade screwdrivers
- claw hammer
- bit-brace with drill bits and countersink
- putty knives
- pocket knife
- As many clamps as you can find, borrow, or afford to purchase (all types: c-clamps, spring clamps, bar clamps, etc.)
- bevel gauge
- tri-square
- wood chisels

Add these tools to make life easier:

- 3/8" reversible power drill
- cordless power screwdriver
- electric circular saw
- saber saw
- 10" table saw with ripping blade
- saw horses

Even better - all above combined with the following:

- 12" portable planer
- hand power planer
- drill press
- miter power saw (chop-saw)

Best of all: Norm's New Yankee Workshop

Shop Safety

The first rule in shop safety is to always wear safety glasses or goggles. Protecting your eyes from flying debris is of paramount importance, yet all too many people (including many professionals) seem to neglect this practice. My suggestion to you is to purchase the best safety glasses that you can afford, and then make sure you wear them whenever working with tools.

Make sure all of your cutting tools (chisels, knives, etc) are always very sharp. Dull cutting tools require more pressure, which in turn may cause them to slip resulting in serious injury.

Shop cleanliness is also an important safety factor that you should be aware of. Sawdust, wood shavings, dirty rags, etc. all create a fire hazard. They should be cleaned up often, and properly disposed of.

Keep a few fire extinguishers handy in easy to reach locations near the exits of your shop. Make sure that they are clearly marked, and that you are familiar with their operating mechanisms. Inspect them often, and have them properly serviced when their gauges start to show less than a full charge. It would also be wise to install a couple of fire/smoke detectors in your workshop.

Have your electrician install ground fault interrupter circuits in place of the electrical outlets in your shop if you don't already have them. They can help prevent serious electrical shocks and burns in the event that one of your power tools or cords become defective.

Provide as much light as you can afford. A bright shop with plenty of light is a joy to work in and is much safer when you can see what you 're doing. A dark, shadowy shop is an accident site waiting for its next victim.

Wear gloves and eye protection whenever using glues and epoxy resins. You should also keep your skin covered completely such that no resin can come in contact with it. You would also be wise to read, and make sure you understand what to do (if your body does come in contact with the product) from the manufacturer's directions BEFORE using these chemicals.

Design your shop to have good ventilation. You should have a good exhaust system, air supply from outside, and a dust collection system (the ideal scenario).

Don't forget to have a good respirator on hand, or at least some disposable dust masks. The sawdust from some woods can be very dangerous to your health, as is epoxy dust from sanding operations.

Remember to ALWAYS read and follow the manufacturer's guidelines in the use and safety instructions for all tools -- both power tools and hand tools.

Keep a list of emergency phone numbers nearby that anyone not familiar with your shop can easily locate, along with a phone, and first aid kit.

Warning: The misuse and mishandling of tools can cause serious injury and even death. Check the condition of your tools and power cords often. Always store your tools properly and never set them down where they may fall to the ground. Never step or stand on electrical cords. Never force any tool to do its job.

Reading and Scaling the Drawings

Reading the drawings means interpreting all of the information that is presented on the drawing sheet(s) so that you know how to build the boat as designed. Don't get apprehensive. I purposely designed Simple Simon to be easy to build, and made the drawings such that the first time boat builder will be able to understand them.

You won't find any table of offsets in the conventional sense, nor will you find conventional lines drawings. They are not needed to build this boat. I've already performed the lofting, made the necessary corrections, and have worked out the dimensions for the expanded side panels. This saves you from a lot of work. Simply transfer the dimensions given in the drawings to the plywood full size.

This design is a very simple hard chined, flat-bottomed skiff. There are no compound curves in the simple plywood construction required of this design. My intention with this design is to focus your energy on actually building this boat simply, and without any confusion. There are many boat building books and manuals available that go into depth on the theory and application of lofting, with detailed instruction on how to go about it. I want to provide you with a way to build a boat such as this with simple, uncomplicated instructions – the idea being you’ll be motivated enough to actually pick up some tools & start building.

There are little tricks to drawing your lines full size on the plywood with a fair degree of accuracy, but I’ll explain exactly what to do during each step. There are also notes and comments on the plans giving you some helpful information in building your boat. Read all the notes and look over the plans a few times. Becoming as familiar with the plans as possible will make the job go easier with less confusion.

From time to time, you’ll want to check some dimensions against the scaled drawings. There will also be times when a dimension you need will have to be taken from the plans. No problem. This is called “scaling the drawing”. When you see a note on the drawings that says; (Scale: 1½”=1’) it means for every one and one half inches of actual measurement on the drawing, the same distance would be equal to one foot in the real world. The same scale also means 1/8” measured on the drawing is equal to one inch in actual size. This is also called 1/8th scale, because the drawing is 1/8th of the actual size.

When scaling from the drawings, the work is so much easier when you use an architect’s scale. An architect’s scale is a three-sided rule that has various commonly used scales applied to each edge. For example, you can read the 1/8th scale with graduations given in “real world size”. If you were to measure something that was 1-1/2” long on a 1/8 scale drawing, and you were using the 1/8th scale on an architect’s scale, it would read 1’ or 12”. If you measured 3/4” actual distance, the scale would read 6”, and so forth.

Make sure if you use a scale, it’s an architect’s scale. The architect’s scale is graduated in feet and inches. If you use an engineer’s scale, it will be graduated in tenths of a foot or inch. The scale will be marked “architect” or “engineer”. Look for these words before you buy your scale (available at any drafting supply store and outlets such as Staples & Office Max).



Whenever you see the letter “L” superimposed over the letter “C”, it is a symbol for the term “Centerline”. The centerline is an imaginary line running exactly down the middle of the boat from the bow to the stern. Centerlines are also used as a guideline to measure from. You will find it helpful to use centerlines when laying out various parts of your boat on plywood panels.

The “Baseline” is another term that you’ll want to become familiar with. This is a line used as a reference point from which to measure from. The baseline is usually a horizontal line located just below the boat on the drawing.

“Station lines” are vertical lines that are drawn perpendicular to the baseline, and there are usually several of these. They are not always spaced in equal distances from each other, so always pay close attention for special notes or measurements on the large scaled drawings.

I know for a first time boat builder, all of this may seem a bit threatening. Take your time; look at the pictures in this book. Look over the drawings in the plans. Follow the instructions I’m about to give you in the next section of the book, and the job should go quite well.

Hull Panels

If you participated in the design segment of this course, you measured, cut out, and assembled the hull panels for

Simple Simon. You did this using card stock, and you cut out the hull panels in 1/12th scale.

Now you are building Simple Simon full size. Instead of card stock, you will measure and draw the side panels full size on a 4'x8'x1/4" sheet of fir plywood. You will then cut the panels out with a power saw or hand saw instead of using scissors. Make sure you use the dimensions given in the Simple Simon boat plans. Do not use the dimensions given in the design and model making exercises. Drawing numbers SS8-001 through SS8-009 contain the proper dimensions you need for the various full sized components you will be pre-fabricating prior to hull assembly.

Put the two side panels together with the inner sides facing each other, the two "good" sides outboard and opposite each other.

Drive one 3/4" dry wall screw through the two sides at each end to hold the panels together in exactly the same position. (Don't worry about the screw holes. You can fill them with thickened epoxy later on.)

Use a block plane (make sure that you have a very sharp cutting blade), and start working the material that's outside the original lines of the panels such that they match each other. You will now be taking off wood - right on down (but not past) the line, making sure you hold the plane perpendicular to the panel side so each panel will match the other like a mirror image.

Now is a good time to measure and draw the location of the main frame if you haven't already done so. You can then set the side panels aside until you are ready to begin hull assembly.

Cutting Out and Fabricating the Transom and Beveling

The transom is fabricated from a 1/4 sheet of 3/4" plywood.

Simply lay out the lines on the plywood using the dimensions given in the plans, and then cut out the transom, leaving just about 1/16th of an inch proud.

If you have a band saw or a hand held saber saw, you can set these for the proper angles given in the plans, and then cut the bottom and side bevels. Note the bevels face outboard. Setting the bevel angles on your saw is no problem either. You'll see the necessary bevels drawn and marked on the drawings. Simply adjust your bevel gauge to the applicable angle shown on the drawing, and then use the bevel gauge to set the tilt of your saw blade.



You can then dress up the transom with your block plane, right on down to the lines.

The transom can be set aside with the side panels until needed.

Cutting Out the Bottom Panel

Getting the shape of the bottom marked on the plywood for the bottom panel is just as easy as the side panels.

It involves a few simple steps to drape a sheet of 4'x8'x3/8" fir plywood over the partially assembled hull, and tracing along the hull on the underside of the plywood with a pencil. Then you turn over the plywood, and cut out the bottom panel.

Cutting the bottom out is pretty much like cutting out the side panels; however you want to leave plenty of material beyond the lines - all the way around the sides of each panel. The reason for this is because everyone seems to measure things a little bit differently. By leaving the excess material that can be trimmed later, there is less chance of wasting a good sheet of plywood.

Don't worry about marking the bottom panel or cutting it out just yet. Later on when it's time that you'll need it, the entire process will be explained in detail; step by step.

For now, this brief explanation should suffice to keep you from thinking there is a missing drawing. There isn't.

Fabricating the Stem and Main Frame

The stem is straight, and has no curvature to it. This makes it quite simple to make providing that you have the right tools; otherwise it will be a bit more difficult. It's a good idea to make your stock a little longer than needed so the ends of the stem extend a few inches beyond each end of the measurements given in the plans. You can always trim off the ends with a handsaw (cross cut saw) later after it's installed, and this will allow for a great looking fit.

Take your stem stock and mark a centerline right on down the entire length on the side where the bevels will be cut. Then mark the bevel angles on the ends of the stock. (You'll find the measurements and bevel angles you need on the drawings).

If you have a table saw or a band saw, fabricating the stem will be a cinch. If you don't have either of these, you can still cut the stem bevels by hand. Cut the bevels on each side with a handsaw (rip saw), leaving a little material proud. You can then smooth the bevel on each side with a jack plane on a tool bench until you get down to the line. This takes more time and effort, but is not all that hard in terms of skill.

If you are fortunate enough to have power tools, just set the blade of the table saw or the table of the band saw to the proper bevel angle with your bevel gauge, and run each side of the stem through. You should still leave a small amount of material proud beyond the lines though, and then dress down the bevels with a jackplane on the tool bench.



That's all there is to fabricating the stem. The main frame can be cut out of one piece of 3/4" thick plywood or it may be optionally fabricated with dimensional lumber. The following instructions are offered if the fabricated dimensional lumber main frame is desired.

I think the easiest way to make up the main frame is to lay out the lines for the frame first on a scrap piece of plywood.

Use the factory-machined edge of a piece of plywood as your baseline. Draw a perpendicular line in the middle of the plywood from the baseline with a T-square and mark it as your centerline.

Layout and assemble one frame component at a time. Measure up from the baseline the distance indicated in the plans and draw a parallel line across the plywood. Then measure out from the centerline (along the horizontal line you just drew) and make a mark on each side. Measure out the distance given from the centerline (along each side of the baseline) and make marks there also. Join the upper marks with the lower marks using a straight edge on each side of centerline. You now have the outside profile of the main frame drawn full size on the plywood.

Measure inboard from each diagonal line 1-1/2" (the width of the main frame diagonal members) and draw parallel lines. You can continue drawing the frame at this point, or you can choose to cut out the two frame pieces to fit the profile you just drew on the plywood.

Measure up two inches from the baseline and draw a parallel line from/to each inside diagonal line. You now have the profile of the bottom main frame piece. Go ahead and cut it out of your wood stock if you'd like.

Cut out a couple of plywood gussets measuring about 6" from the chine towards the centerline, and about 6" from the chine upwards along the diagonal towards the sheer. You can make the frame gusset with scrap 1/4" plywood and make it triangular if you wish. I prefer to put a few curves in my gussets just for aesthetic appeal.

Lay some waxed paper under the areas where the frame parts join together on the plywood base that you drew the frame profile on. Then superimpose the frame parts over the drawing on the plywood. Make sure all the parts fit properly. If they don't, you'll have to sand, plane, or cut them until they do.



Coat all areas of the frame parts that contact each other with thickened epoxy, and reassemble them over the waxed paper on the plywood in line with the drawing. Clamp the parts down on the plywood by driving drywall screws right on through them and into the plywood (you can fill the holes later with thickened epoxy). You can then butter the backside of the gussets with epoxy and nail them into place with bronze anchor-fast nails (you can use wood screws if you prefer). Use about six nails on each frame part for a total of twelve on each side of the frame. Make sure that you don't put any nails in the area (lower outboard corners) where the chine notches will be cut out (if you are opting to build your boat with chine logs using the glue-n-screw method, rather than the stitch-n-glue method).

With the gussets nailed into place, the frame will stay in its proper position and alignment until the epoxy sets up, so you don't have to wait around. Simply unscrew the frame parts you temporarily fastened to the plywood with drywall screws (and you can now fill the screw holes with any leftover thickened epoxy at this time), and set the frame aside, allowing the epoxy to cure.

Sand off the excess drips and sags after the epoxy has cured.

Check the drawings and mark the bevel on each outboard side of the main frame. (The bevel faces forward on the frame). You can set your table saw, or band saw with the proper bevel using your bevel gauge and cut as before, leaving just a little material proud so it can be finished with a jack or block plane. Again, if you don't have these power tools, you can use a rip saw, and then plane to finish. (There's not that much material to remove – I'd use a jackplane from start to finish and not bother with the rip saw).

Pre-fitting the Hull Parts

Position three saw horses in a triangle on your shop floor. All three saw horses should be the same height and level. The floor should also be fairly flat and level also. If not, you'll have to make up a few shims and level the horses. Position them such that the stem will rest on the forward horse, and the stern of the side panels will rest on the aft horses.

Fit the stem and one side panel together temporarily with a couple of drywall screws. Let the stem (that you cut extra long) protrude beyond the top and bottom of the side panel. Pre drill and countersink screw holes through the hull side and into the stem for #8 by 1" wood screws. Allow about 3-inch distance between holes. Mark the top and bottom location of the hull side onto the stem bevel with a pencil.

Remove the drywall screws and disassemble.

Locate the opposite hull panel on the other side of the stem, and align it with the pencil marks. Drive in a couple of drywall screws, and pre-drill & countersink as before. Disassemble, and clean off the wood chips from the drill holes in both panels, and stem.

The remainder of the boat's components are pre-fitted, and pre-drilled just like the side panels and stem. Always disassemble the components afterwards so that you can brush away wood chips and sawdust resulting from drilling and countersinking holes. This practice may take more time, but will allow the parts to fit better, and produce a neater looking job.

Assembling the Hull Sides, Frames, Stem, and Transom

Mix up some "shmoo" (epoxy thickened with Cabosil, wood flour or similar filler), and apply it to the stem on just one side for now. On the side panel to be joined to the stem first; drive a couple of drywall screws into existing holes until they protrude on the other side of the panel - about half way. You will use these drywall screws as locating pins you will line up with existing holes in the stem. Run these screws all the way in after getting them started (by hand) so the panel is tight against the stem. You can now install the #8x1" stainless steel wood screws. Remove the locating drywall screws afterwards, and replace them with stainless steel wood screws.



Use a rag to wipe off all the excess epoxy that has squeezed out. (Get in the habit of always wiping up excess epoxy after each gluing operation and it will save you all kinds of time later as there will be less to sand).

You can now join the other panel to the stem in the same fashion; however it will be a bit tricky; you will have to hold each panel upright rather than lying flat. It's a good idea to have someone help you hold the panels at this point. I usually do it by myself, but an extra pair of hands would be ideal. Another tip to help this operation go smoother is to join the panels to the stem with the boat's bottom edge of the panels facing up. The remainder of the assembly procedure will require the boat is built upside down so starting off this way will require less handling.

Once the panels are glued and screwed into place at the stem, you can relax, take a break, and prepare for the next job.

Next, you will pre-fit, pre-drill, countersink for #8x1" wood screws spaced about every three inches, and install the main frame using the same technique used to install the side panels to the stem. There is however one exception to this. The main frame is first aligned and clamped into position against the side panel for pre-drilling/fitting using c-clamps. After one side has been drilled, unclamp the frame, and follow the same procedure on the other side.



Once the frame has been marked and drilled, remove it from the hull sides. Now you can mark the locations of the chine notches, and cut them out if you are using the glue-n-screw method. If you are incorporating the stitch-n-glue method, you won't have to install chine logs. You should cut the proper clearance as shown in the drawings to allow for fiberglass taped seams instead.

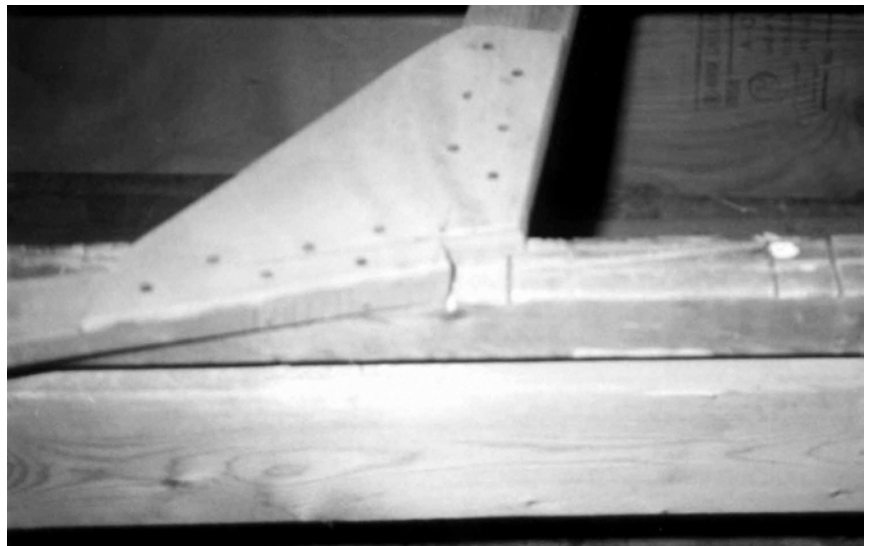

Now bring the sides in together equally. This is done using a device known as a "Spanish Windlass." Very simply, it's just a length of rope or line wrapped around the hull's sides and tied together with a knot. You then place a stick between the top and bottom line that is stretched across the hull panels and start twisting it until the panels come closer together.

Align the side panels with the main frame using the drywall screw locating method, and fasten as before with epoxy, and stainless steel screws.

You can check to make sure everything is aligned properly to this point quite easily. Par-

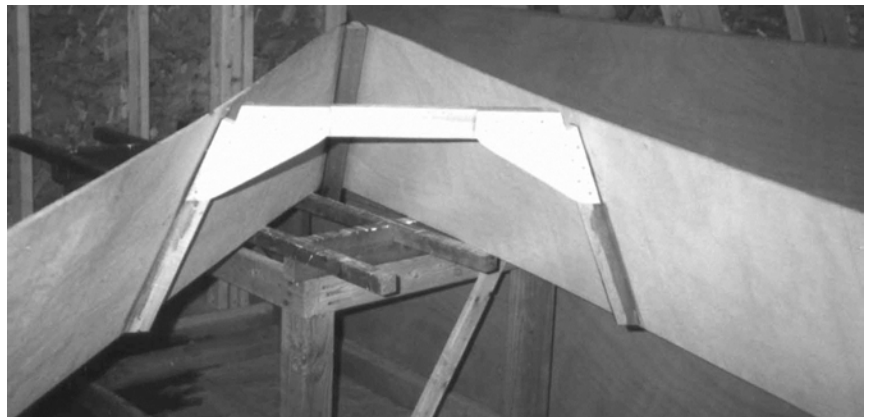

tially drive a small nail into the stem at centerline. Then tie a string to the nail and pull it taut to the point where the leading edge of the forward frame comes in contact with the side panel. Mark the string with a magic marker, and then move the string to the opposite side at the same point. If you are within 1/16th of an inch or so, I'd say that's pretty good! If you're off quite a bit, you'd better loosen up the wood screws holding the forward frame in place and make whatever adjustments you need before the epoxy starts to set up.

Once you are satisfied with your assembly and the epoxy has cured, you may continue assembly by installing the transom in the same fashion as the main frame.

Use a "Spanish Windlass" to draw in side panels to fit transom, then permanently glue and screw it into position. Remember, the transom bevels face aft.

Don't forget to cut the limber holes in the main frame.

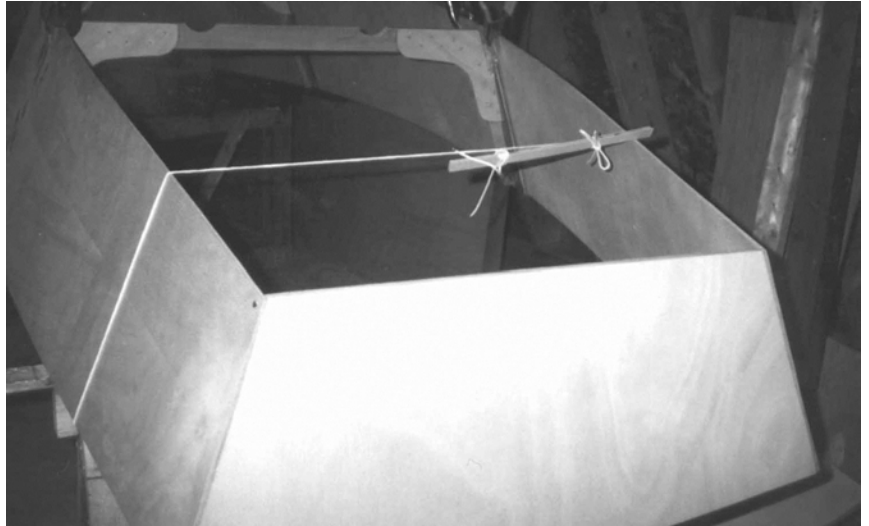

Checking the Hull for Symmetry

If you've been checking the hull for symmetry all along at each frame and at the transom as you went along, you should be in pretty good shape.

There is one other possible problem that you should check for before you apply the bottom panels.

If the sawhorses have not been sitting level on the floor, it's possible the hull may have become racked or twisted during its assembly. The thing to do now, besides rechecking for symmetry between the bow and the outer ends of the stern, is to sight along the bottom surface of the hull.

All of the bottom edges of the frames and transom should look absolutely parallel. If they aren't, your hull may be racked.

At this stage of assembly, slight racking (twisting) can be fixed easily. Simply leveling the sawhorses should do the trick. Be careful though. You still have to install the chines (which can distort the hull a little during the process). You should check for hull symmetry and distortion through each step of assembly until the hull is completely built.

One thing to remember: When you are installing the chines, the hull will be distorted slightly with only one chine in place, but should equal out after the other is in, so don't panic.

Fitting and Installing Chines

If you are using the stitch-n-glue method of construction for joining the bottom panel to the side panels and transom, you won't need this section. If you opt for the glue-n-screw method, you will have to install chines to allow solid material for screws to bite into while the epoxy cures, holding the side panels, transom, and bottom panel all together.

The chines are longitudinal stiffeners running from the stem to the transom along the lower edge of the side panels, and join the boat's side panels with the bottom panels. They also act as a cleat to drive fasteners into. Chines are a

very important part of all my skiff designs, so take your time with this segment of the building operation.

This part can be a little confusing and sometimes difficult if you've never fitted and installed a chine after the hull sides are already assembled. Fear not. Just go over this part slowly, and double-check everything you do. Once you've fitted and installed a chine on one side, the other will be a snap.

Since there is more than one method of fitting chines to a hull, I'll just tell you how I do it. Maybe you'll develop an easier way.

Using your bevel gauge; set the angle by placing the bevel handle or base flat on the bottom edge of the side panel at the bow. Then adjust the bevel's blade to the downward, away-sweeping angle of the bow. Be careful with this setting and make sure that the adjusting nut is tight.

Take the first piece of chine stock that is a foot or two longer than what is needed (check the specification on your drawings for the correct dimensions) and transfer the angle you just measured onto the forward end on the wide side of the chine stock using a pencil.

Using your bevel gauge once again, place the tool's handle facing in an aft direction and flat against the side of the hull's side panel along the chine edge at the bow. The bevel gauge will appear to be in a horizontal position when you do this. Adjust the bevel's blade straight across, such that it is in line with the back edge of the stem. In fact, you should set the bevel with the blade right up against the stem. Now transfer this angle across the thin side of the chine stock with the end of the line meeting the first line you drew across the wide section at the corner of the chine stock. You now have a compound bevel that you have to cut.

Adjust your saber saw to the angle you just set on your bevel. Do this by placing the handle of the bevel flat against the bottom plate of the saw, and adjusting the angle of the saw blade until it is parallel with the blade of the bevel.

Now saw along the first line you drew on the chine stock.

You now have a compound bevel cut on the end of the chine stock that should fit tight between the side panels and stem. If you don't, re-read this section, scratch your head and try it again.

With the trimmed/beveled chine end against the stem and side panel, work your way aft, tucking the chine in between the frame's chine notches and side panel, but allowing the excess chine stock to overhang the transom. You may find it much easier during the fitting process to clamp the chine up against the inboard side of the side panel with C-clamps and 2" spring clamps – about a dozen of them.

Now make a pencil mark on the chine stock at the after edge of the main frame. Remove the chine.

Check the bevels and make the compound bevel cut at the stern end of the chine where the side panel meets the transom

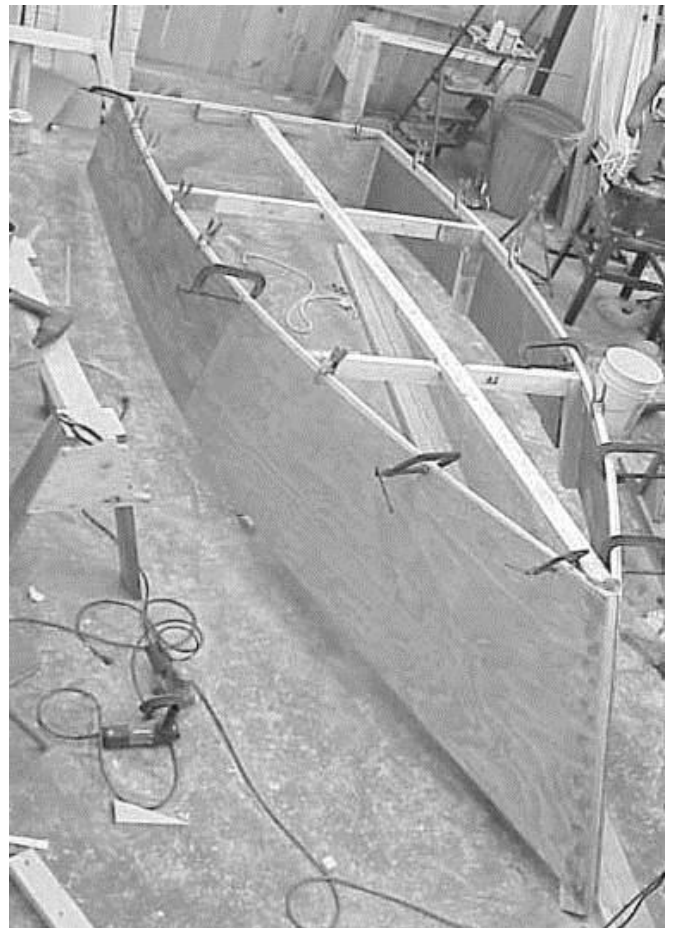

employing the same technique used at the bow. Note that the extra length of chine stock will now extend beyond the bow. Check the aft end of the chine for a proper fit at that end. Then install the rest of the chine heading forward with the clamps, leaving the excess chine to overhang the bow end.

Make another mark on the chine at the aft edge of the main frame. Measure the distance between the two pencil marks you made on the chine. Cut off this same distance from the aft end of the chine using the same bevel and saw setting as before. The chine should now fit perfectly.

Clamp up the chine in its exact final position with the spring clamps. The outboard edge will be standing proud of the side panel edge about an eighth of an inch or so.

Now pre-drill and countersink holes through the side panel and into the chine for wood screws about every 3½" to 4" or as specified in the drawings for the boat you are building.

Remove the clamps and chine from the side panel, and dust off the wood chips.

Apply thickened epoxy to the outboard face of the chine that will fit against the inside of the side panel, and then install the chine. Clamp up the chine with the spring clamps to help hold it in position as you install it. Drive in the stainless steel screws and then wipe up any excess epoxy.

Repeat this whole process for the chine installation on the opposite side of the hull.

After the epoxy has cured, plane down the excess chine material that is standing proud of the hull side panels such that the bottom profile has a flat surface. (Keep checking this with a straightedge across the bottom in various locations up and down the hull).

Drawings DD-9 through DD-12 depicts the various stages of chine fit-up and installation.

Step One, Fitting Chines

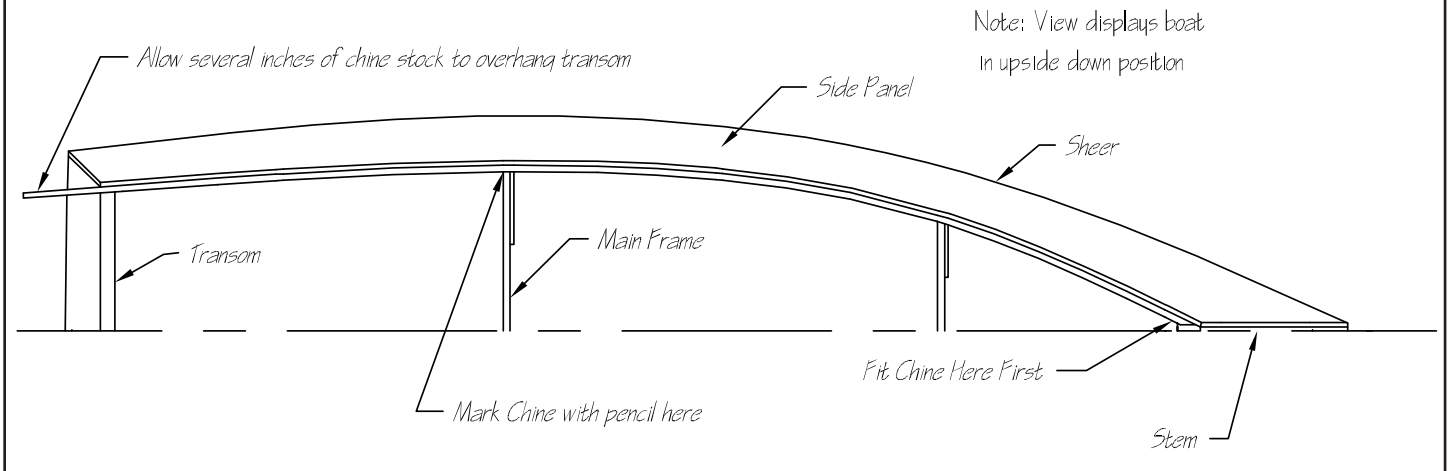

Step Two, Fitting Chines

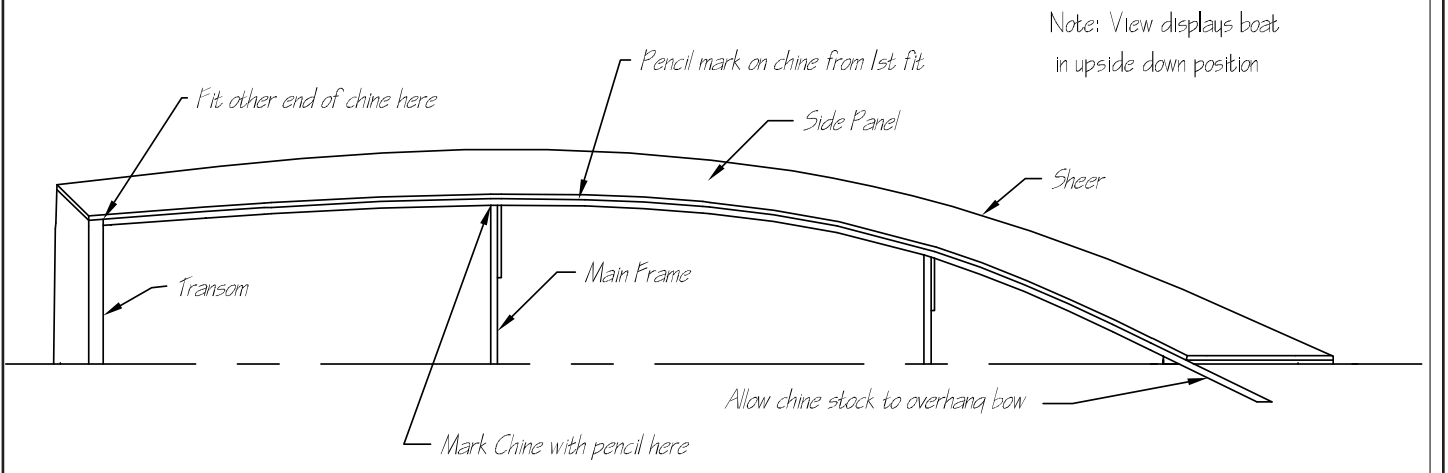

Step Three, Fitting Chines

Remove chine log from hull, measure and cut, reinstall as shown below

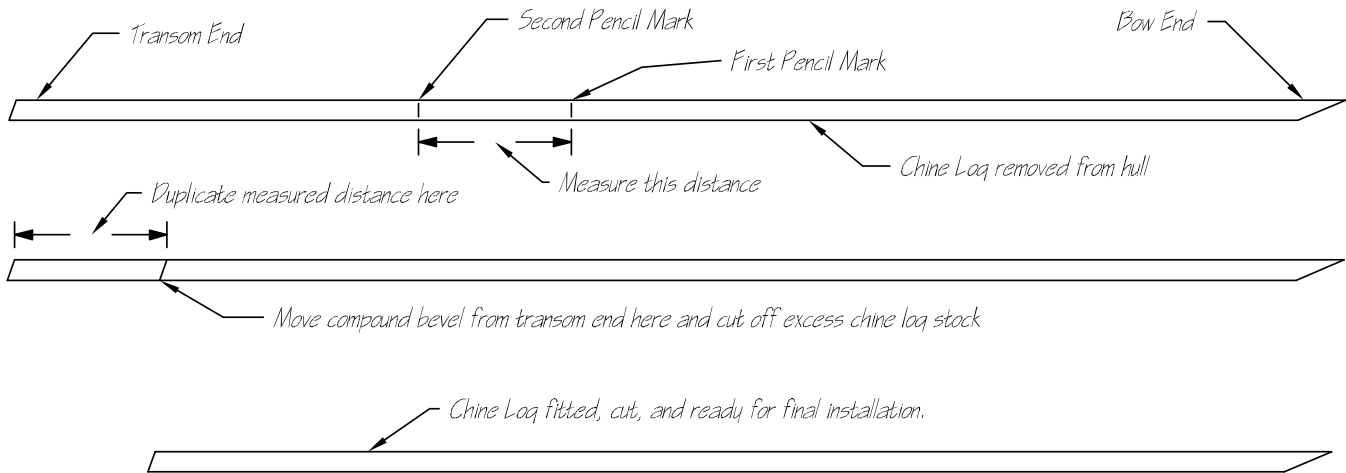

Step Four, Fitting Chines

Note: View displays boat in upside down position

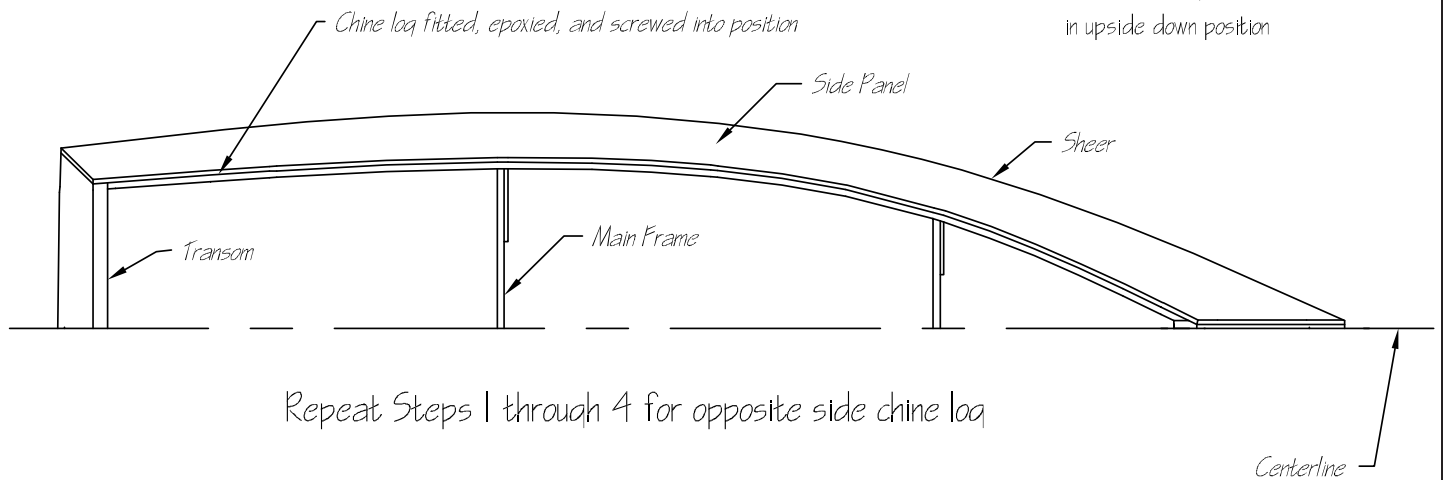

Fitting the Hull Bottom

If you haven't already planed down the excess chine material, and checked the bottom for a flat surface across the sides – do it now. You should also make sure the side panels are flush with the bottom of the stem (cut off the excess stem if you haven't already done so), and the transom (plane or sand as necessary).

Take a full sheet of 4'x8'x3/8" marine plywood, and drape it over the bottom of the hull. Align one end of the plywood with the aft edge of the transom, allowing the plywood to stand proud about 1/8th of an inch. You should also align one long side of the plywood with one side of the hull, and again let the plywood stand proud a bit.

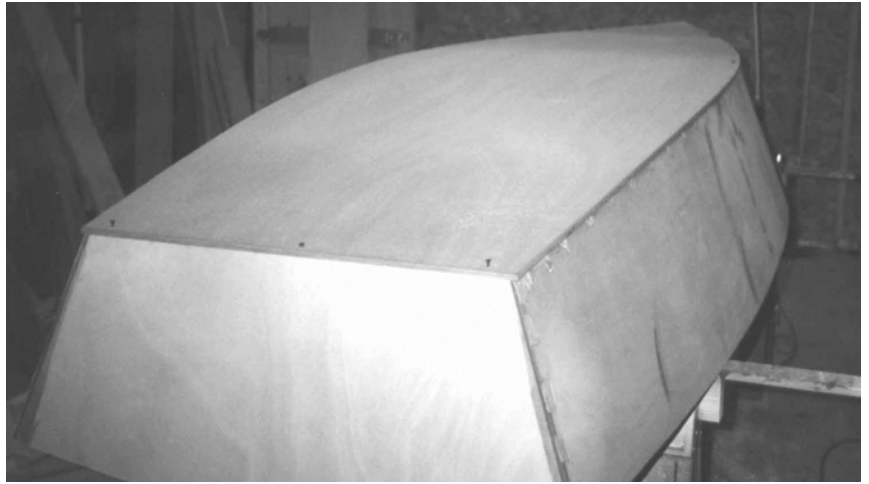

Temporarily hold down the plywood against the hull bottom using a few drywall screws at the transom and then work forward. The plywood should now be flush against the bottom.

Take a sharp pencil, and trace along and against the hull sides on the underside of the plywood.

Remove the plywood, turn it over, and cut along the outboard edge of the traced lines – staying about an eighth to a quarter of an inch away from them.

Re-install the bottom on the hull with the drywall screws. Drill and countersink along the bottom into the chine every 3½" to 4" for #8x 1" stainless steel wood screws. Also drill and countersink through the bottom panel into the main frame, being careful not to drill into the location of any limber holes (see drawing).

Remove the bottom panel and clear away the wood chips.

Apply thickened epoxy to the bottoms of the chines, transom and stem. Re-install the bottom panel, using the drywall screws and holes as locating pins & to hold the panel in place. Now drive in the stainless steel wood screws.

After the epoxy cures, sand off any excess epoxy drips along the sides, and use a jack plane to trim the overhanging rough edges of the bottom panel such that it is flush with the side panels. Sand smooth and slightly round the top edge of the bottom panel all the way around.



Now is a good time to remove all the drywall screws.

Glass Taping the Hull Seams

Get a roll of 3” or 4” wide fiberglass tape, and roll it out across the hull along the transom/bottom seam and cut off a piece to fit.

Start at the bow and unroll along the chine, and cut at the transom. Repeat this on the other side. You now have your fiberglass all measured out.

Mix a container of epoxy that is un-thickened. Use a disposable paintbrush and wear protective plastic gloves & eye protection. Paint on the epoxy along the seams, (transom, and chines).

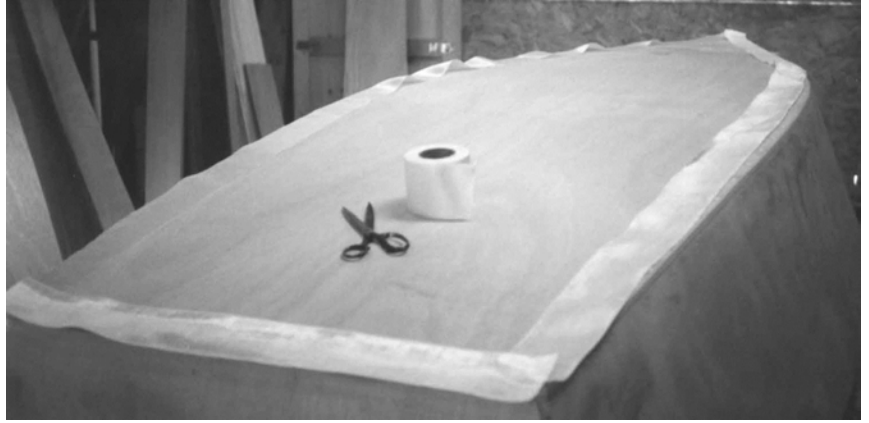

Lay the glass tape in place over the chines, and transom seams. Paint another generous coat of epoxy onto the top of the glass tape.

Work the epoxy into the tape so it turns clear, and you get it laying flat. Then make sure you get out any and all air bubbles that might be trapped under the glass tape. This can be accomplished by “poking” the glass tape with the bristles of the brush. It will become more difficult to do this as the epoxy begins to click off, so working quickly and efficiently is key.

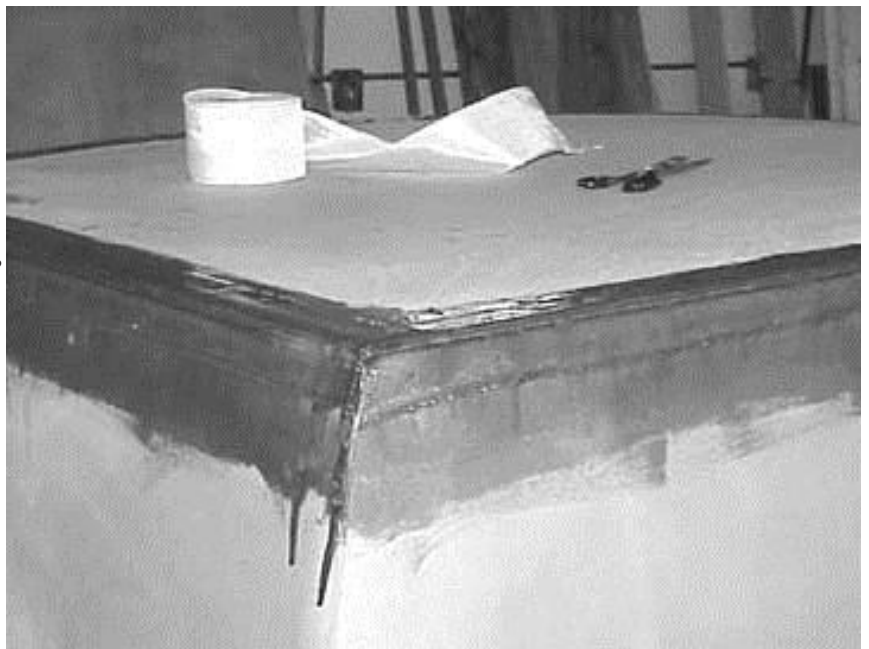

Allow this to cure overnight, however you should check often immediately after applying the glass tape to remove any sags or runs down the sides of the hull. This practice will save you a lot of time sanding later on.

This is just a rough guideline to follow. You should consult the instructions from the manufacturer of the brand of epoxy that you are using for more specific information and technical information.

When the epoxy has cured on the glass tape around the bottom, sand off the excess material, and brush it all off to allow a clean surface.

Mix some epoxy with sanding filler compounds, and apply with a squeegee like the type used with Bondo in body shops – all around the sides and edges of the glass tape to “fair” it to the hull (make the tape blend into the hull). Sand the surface when cured. Repeat as necessary until you can't tell that there is glass tape applied to the hull.

Fitting the False Stem

Fitting a false stem is optional. Most people fill the stem seam with thickened epoxy, apply glass tape over the seam, fair the edges of the seam, and call it good. Others like to affix a strip of wood (false stem) as an outer trim piece. If you opt for the false stem:

Plane down the front of the stem with a jackplane, making the surface a uniform width, and smooth. The surface should also be flat.

Use a piece of oak or mahogany about $\frac{3}{4}$ " thick by 1" wide. Pre-drill and tack into place temporarily with brads. (Slather epoxy on the under-face and also on the stem face). Make sure that the wood used for the false stem extends a couple inches at both ends (you can always trim to size later).

When the epoxy cures, remove the brads, and plane on each side such that the false stem is flush with the hull's side panels. (Fill the nail holes with thickened epoxy). The false stem may be painted or finished bright.



Fabricating and Installing the Keel

You'll need a length of $\frac{3}{4}$ " x $\frac{3}{4}$ " mahogany or white oak about 8' long, or at least long enough to overhang the transom and stem when placed on the bottom's centerline.

Marking the centerline is simple: Start a small nail at the centerline in the stem and measure/mark the mid-point of the transom with a tape measure and pencil. Then snap a chalk line from stem to stern by clipping one end of the chalk line to the nail, and stretching the chalk line over the pencil mark at the stern, then snapping the line once with your fingers.

Drill starter holes in the hull bottom along the chalk line for #8 wood screws but do not countersink the holes at this time. The holes should be spaced about 6" apart from stem to transom.

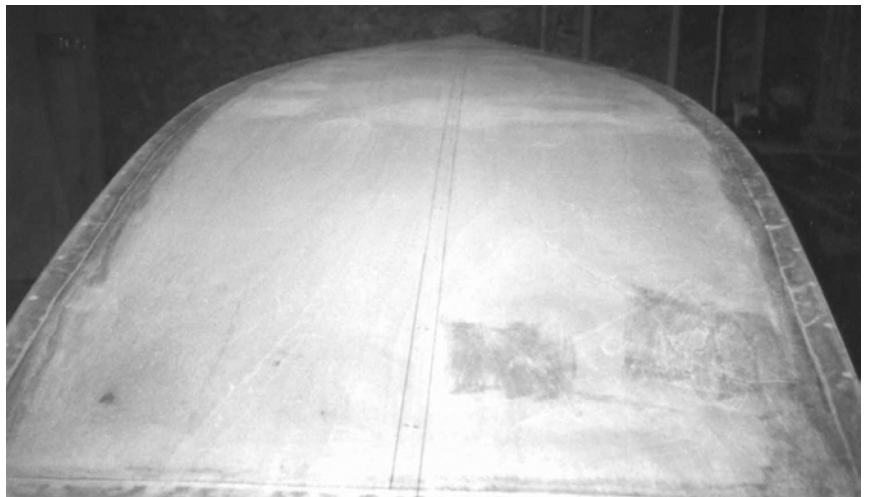

Place the mahogany strip over the centerline with the aft end protruding beyond the hull (you will trim off the excess later); the forward end should be butted up against the protruding part of the false stem you haven't trimmed yet. You may have to trim the forward end of the keel piece at an angle to fit flush against the false stem. Do this now.

Temporarily screw down the mahogany strip with a few drywall nails. Turn the hull over so it is right side up.

Re-drill the starter holes from inside the boat for #8x1" wood screws with countersinks. Turn the boat back so that it's upside down.

Remove the drywall screws and mahogany strip. Clean off the wood chips and sawdust.

Apply thickened epoxy to the bottom of the mahogany strip, place it back down into position on the hull using the drywall screws to locate and fasten it.

Turn the boat right side up once again. Install the #8x1" stainless steel wood screws. Turn the boat upside down again. Remove the drywall screws and fill the holes with thickened epoxy. Wipe up the excess epoxy that has squeezed out.

You now have a keel (Don't forget to trim off the excess wood after the epoxy cures).



Fabricating and Installing the Skeg

Consult the plans for details of the skeg. Trace the shape onto $\frac{3}{4}$ " thick mahogany or white oak and cut it out leaving about $\frac{1}{16}$ th of an inch proud beyond the traced lines.

Check the fit of the skeg on the keel at the aft end of the boat. Use your block plane to trim the excess wood, and perform the final fit of the skeg to the keel.

About 1-1/2" aft from the forward part of the skeg, drill and countersink a hole through the skeg and into the keel for a #8x1-1/2" stainless steel screw. Temporarily use a drywall screw in that same hole to hold the skeg in position for now.



Drill through the aft edge of the skeg and countersink for another #8x1-1/2" stainless steel screw. Install another temporary drywall screw. Turn the boat over such that it's right side up.

Drill through the bottom, and keel, into the skeg for #8 x 2" stainless steel screws with countersink. Drill holes about 4" to 5" apart from about 2" aft from where the first "outside/forward" screw is located, heading aft to the transom.

Turn the boat upside down. Remove the fasteners and the skeg; remove wood chips and sawdust.

Apply thickened epoxy to the surface of the skeg that will bond to the keel, then position the skeg onto the keel. Install the #8x1½” stainless steel screws.

Turn the boat right side up. Install the #8x2” stainless steel screws.

Turn the boat upside down. Wipe off all the excess, squeezed out epoxy. Allow the epoxy to cure.

Seats-N-Cleats

I included this section about the thwarts and thwart support cleats because the method used for fitting and mounting thwarts in Simple Simon is unique to this particular boat is not the same as the other Shoestring Shipyard designs.

The first consideration to be made is where the seats (thwarts) will be located in the boat. On a vessel as small as Simple Simon, the location of the seats can be critical as it has a direct effect on the vessel's stability and trim. The size and number of people in the boat during normal use must also be considered. The heaviest person will normally sit somewhere in the middle. A few inches forward or to the rear can mean the bow will dip or rise up. If a second person is added to the boat, this changes yet again. Therefore, it becomes very difficult to determine the ideal location for the seats on such a small vessel.

I have arrived at a general location for the three seats (thwarts) in Simple Simon I think will suit the majority of people, however you should probably make some temporary seats from scrap and try installing them a few inches fore and aft, along with trying different loading combinations with the boat in the water to determine the best arrangement for your application. Once you arrive at what works best for your purposes, fabricate and install the permanent thwarts.

Look at Drawing #SS8-001, paying particular attention to the top view of Simple Simon. This view displays a fairly well balanced thwart arrangement for most people. The back (aft) edge of the back (aft) thwart is about 4” to 6” from the inside face of the transom. This is a fairly good rule of thumb to use in locating the aft thwart.

The amidships (middle) thwart has also been strategically located. The aft edge of the amidships thwart should be located about 2” aft (behind) the rear (aft) face of the main frame.

The forward (front) thwart is positioned with the forward (front) edge about 8” to 10” distance from the aft face of the stem (in the same plane).

The height of all the thwarts is about 8-¾” above the top surface of the bottom panel. This height allows a fairly stable boat with a low center of gravity. The builder can raise the height of the thwarts, so long as the builder understands such action raises the center of gravity, and reduces vessel stability. The height is marked by measuring 8” up from the inside of the chine along the side panel (the remaining ¾” of height is gained from the ¾” thickness of the plywood thwarts).

The thwarts are supported by simple cleats fabricated from 2x4 building studs, and are installed with thickened epoxy resin and stainless steel screws. The thwarts themselves are simply fashioned from ¾” plywood and are secured by screws and finish washers so they can be easily removed for cleaning and painting.

Look at Drawing #SS8-009 for a cross-sectional view of Simple Simon at the amidships location. The cross section of the cleats are shown forward of the main frame.

A standard size 2x4 building stud actually measures 1-1/2" x 3-1/2" (in cross section) around most locations of the USA. If you rip a 2x4 right down the middle, you'll have your cleat stock which will measure close to 1-1/2" x 1-3/4" in cross section. When cutting the bevels and fitting the cleats, cut the cleat stock such that the up & down thickness of the cleat is 1-1/2".

The thwarters are 10" wide, and the cleats should be hidden from obvious view. Cut the cleat stock into 8" long sections to accomplish this. The thwarters will then overhang the cleats fore and aft by 1" and not be readily seen. There is still plenty of cleat material to adequately support the thwart.

Drawing #SS8-009 shows a bevel cut on both sides of the cleat, but only one bevel is actually necessary (the bevel that is placed flush against the side panels). The bevel is found by using a bevel gauge. Place the hand of the bevel gauge flush against the bottom and adjust the blade of the gauge flush against the inside face of the side panel at the midpoint location of the thwart you are working on. (That means the bevel is taken about 5" inboard from the location of one of the thwarters edges).

Since you may have a bump on the inside angle of the chine from the epoxy and glass tape, you may have to place a block of wood on the bottom panel and place the bevel gauge handle on the block of wood to raise the gauge above the chine. This also applies if you have decided to build Simon with a solid chine log instead of the Stitch-N-Glue method.

Use your bevel gauge to set your band saw or jig saw to the proper bevel. Don't cut the cleats yet, as you must also find the curve of the side panel. Place a piece of wood or stiff cardboard about 8 inches long between the two points on the inside face of the side panel which mark the location of the thwart. Note there will be a gap in the middle between the wood and the side panel. Measure and record the distance of this gap. Four inches in (at the center) of the wood or cardboard, draw a perpendicular line (centerline) from the edge. Measure in from the edge the same distance recorded earlier. Draw a line parallel with the edge at this measurement location. Use a thin flexible batten to draw a curve with clothespins or small clamps to hold the batten in position. The batten should be clamped with the inside edge at the outer edge of the centerline and the batten should be bent in towards the parallel line and clamped where the inside of the batten intersects the end of the parallel line. Draw in the curve with a pencil against the inside edge of the batten. Cut out this curve from the wood or cardboard and use it as a template, tracing the curve onto the cleat stock on one side. Now use the pre-adjusted band saw or jigsaw to cut along the curved line. The end result is a cleat with the proper bevel and curvature to fit flush against the side panel so the top of the cleat is level in a horizontal plane.

This procedure is followed for all of the cleats, however you may wish to note the cleats at the amidships position must be cut into smaller pieces to fit on both sides of the main frame.

The cleats are held into position by hand and then checked for a proper fit. If there is only a minor misfit, the epoxy resin will fill the gaps and no further work is required. If the fit is off too much, take your time with a block plane and sandpaper until you are satisfied with the way the cleat fits.

Hold each fitted cleat in position with a couple drywall screws temporarily. Drill and countersink through the side panels into the cleats for #8 x 1-1/4" to #8 x 1-1/2" screws (2 to 3 screws, evenly spaced, per cleat). Remove the cleat, apply thick-

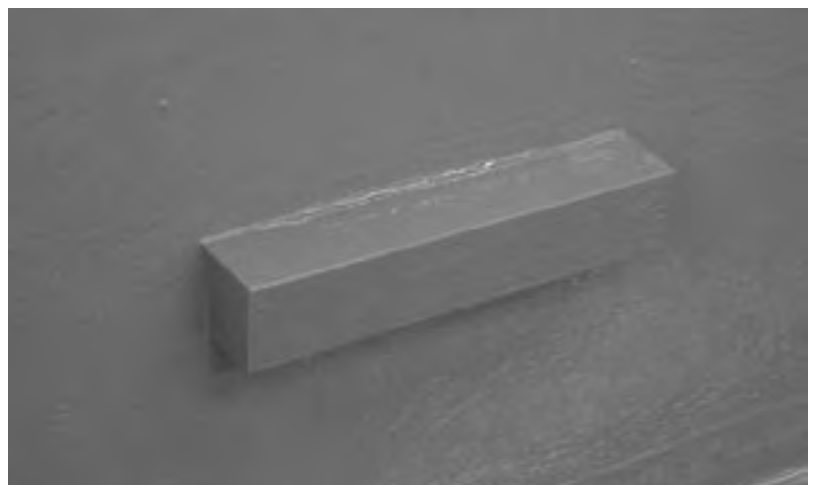

ened epoxy to the mating surface of the cleat, and reinstall with stainless steel screws. Wipe up excess epoxy afterwards. Repeat as necessary until all cleats are installed.

Seats (Thwarts)

The seats take a bit of patience and time to fit properly, however the procedure is easy. The key point to keep in mind is to not rush your work. Taking time with this part of the project will pay dividends in the final appearance of the boat.

Simple Simon was designed to use three sheets of plywood in its construction. The $\frac{3}{4}$ " sheet of plywood yields the mainframe, transom, and stock for making the seats. The 10" wide plywood strips to be used in fabricating the seats should already be ripped from the plywood sheet. If not, do so now before proceeding further. Optionally, you may use Port Orford Cedar, Mahogany, Ash, etc for the thwarts, and finish them "bright" (several coats of marine grade spar varnish). This is a personal decision you must make. Mahogany thwarts look very "yachty", but will of course add to the total cost of the boat.

Measuring and cutting the thwarts to fit properly is much easier to do physically than trying to explain it. The same procedure should be used to fit all of the thwarts, with only one exception for the amidships thwart: You must cut a clearance slot on each end of the thwart for the mainframe.

Use a scrap piece of $\frac{1}{4}$ " plywood that has been ripped into a 10" wide strip. Take rough measurements across the hull from side panel to side panel for the thwart you are fitting. There are two such measurements per thwart. One measurement is the distance across the boat at the location of the thwart's leading edge, and the other is at the rear edge. Transfer these measurements to the scrap plywood strip. Draw a line to connect the measurement pencil marks at each end, and there should be diagonal lines as a result. Cut off the excess plywood along the diagonal lines. Try fitting the thwart into place and trim off any excess wood that interferes with the template sitting flat across the cleats. Once this is accomplished, temporarily hold the template down to the cleats with one drywall screw per side.

You will notice that the template does not allow for the curvature of the side panels and may also reveal large gaps between the ends of the template and the side panels. This is normal so don't panic.

Rip a 1" to 1-1/2" wide strip of scrap $\frac{1}{4}$ " plywood and cut the strip into several lengths, each about 4" long. On one end of each piece, cut a diagonal from one side to the other so you are left with a sharp point on one side of the scrap piece. You now have several pointers.

Use a hot-melt glue gun to attach the pointers using the following instructions (you can also use drywall screws or carpenter's glue): Dab a spot of hot glue onto the face of a pointer and place the pointer onto the thwart template so the pointer's long side is flush with one side of the thwart template at one of the ends and the point of the pointer is against the inside face of the side panel. Repeat this procedure on the opposite side of the thwart template on the same end. Then place a third pointer on the same end but located so the point is in the middle of the thwart and against the inside face of the side panel. This gives you three points from which to develop a curve. Repeat the above operation on the other end of the thwart template.



Remove the thwart template from the boat and lay it over a 10" wide, 3/4" plywood thwart strip. Temporarily hold in place with a couple of 2" spring clamps. Make a pencil mark at each point at each end of the thwart template onto the 3/4" plywood. Remove the thwart template. Connect the dots to form a curve with pencil (using the batten method you learned earlier in the construction process). Do this on both ends of the thwart. Cut out the thwart along the lines (cutting just outside the line such that the pencil mark is still visible).

Try fitting the thwart into position on the boat. If it is too tight for a flush fit against the cleats, trim off a little wood on the ends with a block plane and sandpaper until the fit is satisfactory. The bottom edge of the thwart ends should fit reasonably snug against the side panels; however you will still have a gap at the top edge formed by the angle of the side panels. This is not a concern and will be addressed further in the text.

With a satisfactory fit, round over all the edges of the thwart with a 1/4" round over bit in a router, or round over with hand tools and sandpaper (your own rear end will appreciate this touch later when you are using the boat). Place the thwart back into position. Drill two pilot holes at each end, evenly spaced for #8 x 1-1/2 to #8 x 2" screws. Do not countersink these pilot holes. You will install the thwart with flathead screws and finish washers later, but no glue or epoxy (to facilitate easy removal for painting and cleaning).

Fabricate and fit the remaining thwarts using the same procedures outlined above.

Once all of the thwarts are completed, remove them from the boat and place them over a couple of sawhorses. Sand the thwarts to a smooth finish with #100 grit sandpaper. Apply two coats each (minimum) of primer and finish paint. Paint the thwarts entirely (top and bottoms). Allow thwarts to dry thoroughly between coats and scuffing the surface with a 3M brand, scuffing pad.

Fitting and Installing the Breasthook, Quarter Knees, and Transom Knees

A breasthook, quarter knees, and transom knees are not required for Simple Simon unless you in-



tend to install an outboard motor or install a sailing rig. These components help to stiffen and strengthen the hull to take the thrust of the outboard or the strains from the sail rig. I like to install them regardless simply because I like the looks of them.

A breasthook is a tie between the side panels and stem, usually located at the sheer in the bow. It can be a basic triangle, or you can add a bit of curvature; the option I usually choose.

Quarter knees are ties similar to the breasthook, but are located at the stern usually near or at the sheer and tie the transom to the side panels. There is one on each side of the boat. Again, it can be a basic triangle, or you can put a bit of curvy styling into the design.

Transom knees are only needed if an outboard motor is used. They are ties between the transom and the bottom panel. Sometimes there is just one at centerline, but usually there are two of them about 16" to 20" apart, equidistant from the centerline. Triangular or curvy: Your choice.

These are parts of a boat always inspected by "old salts" and other boat builders to see just how well you made your fits. You'll want to take your time here, but it's really not all that difficult.

You can make up templates for all of these components with card stock or poster board. Once you are happy with the fit of the template, transfer the shape onto wood stock, cut it out and fit the components to the hull.

The bevels along the sides of the breasthook and quarter knees are easily found with your bevel gauge, and the only things left are little details; yet details are what make the difference.

First of all, make sure there aren't any epoxy bulges in the corners where the transom meets the side panels in the aft quarters of the hull. This will cause the quarter knees to lift and look like you didn't cut or fit them properly. Likewise, check for epoxy globs inside the angle where the stem meets the side panels in the area of the breasthook installation for the same reason.

Put the breasthook and quarter knees into place just to see how they fit. You might get lucky and not have to do anything more. Most likely you'll have to do a little trimming though.

The breasthook should fit such that the top of the breasthook surface should be flush with the top of the stem and the side panels. It should also fit snug and tight up against the side panels and against the stem.

If it's not quite right, you may have to saw a little bit, or shave a bit from the sides if they were cut unevenly (use your block plane and/or sander).

Keep repeating this just a shaving or two at a time and keep checking the fit until you are satisfied with it.

When you are ready to install the breasthook, hold it temporarily in place with a couple of drywall screws through the hull sides into the breasthook. Drill through the hull on each side of the breasthook for three evenly spaced

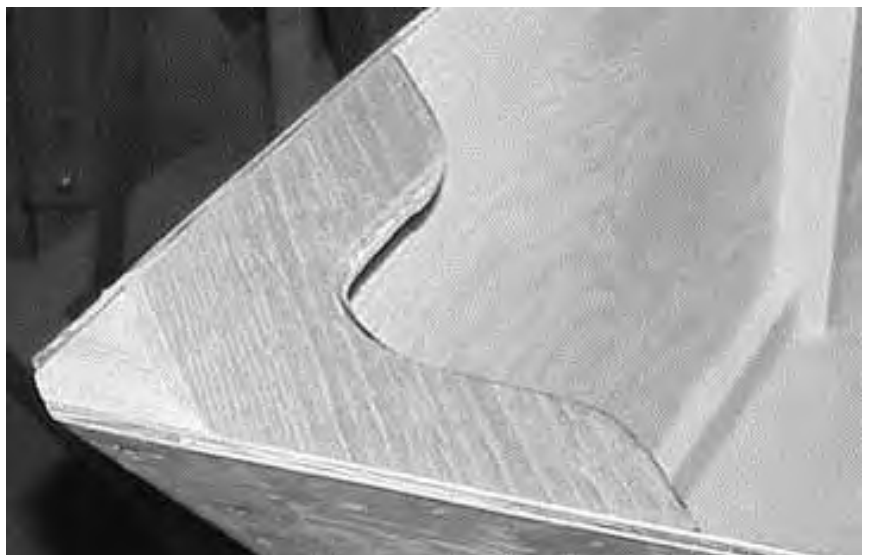

#8x1½” stainless steel screws with countersinks.

Remove the breasthook; slather thickened epoxy on the sides and around the stem notch area, then install using the #8x1½” stainless steel screws.

Wipe off the excess epoxy both top and bottom to save you future sanding work.

The quarter knees are fitted using your block plane in the same way; however they are mounted in a different manner. The sides of the quarter knees are mounted flush with the hull sides, but the aft edge of the quarter knees are mounted about an inch to an inch and a half (depending how your hull has been built) down from the top of the transom. They will almost appear to go straight across, but the transom has a crown in it and will rise above them.

The aft edge of the quarter knees are fastened with #8x1½” stainless steel screws (three of them spaced evenly per side) that are countersunk. The sides of the quarter knees are fastened with three evenly spaced #8x1¼” countersunk stainless steel screws per side.

The installation process with the epoxy and screws is a repeat of the breasthook installation. Always wipe up the excess epoxy afterwards.

Stern knees do not require any side bevels and are perhaps the easiest of these components to fit and install. Fabricate and install in the same way you fit and placed the quarter knees.

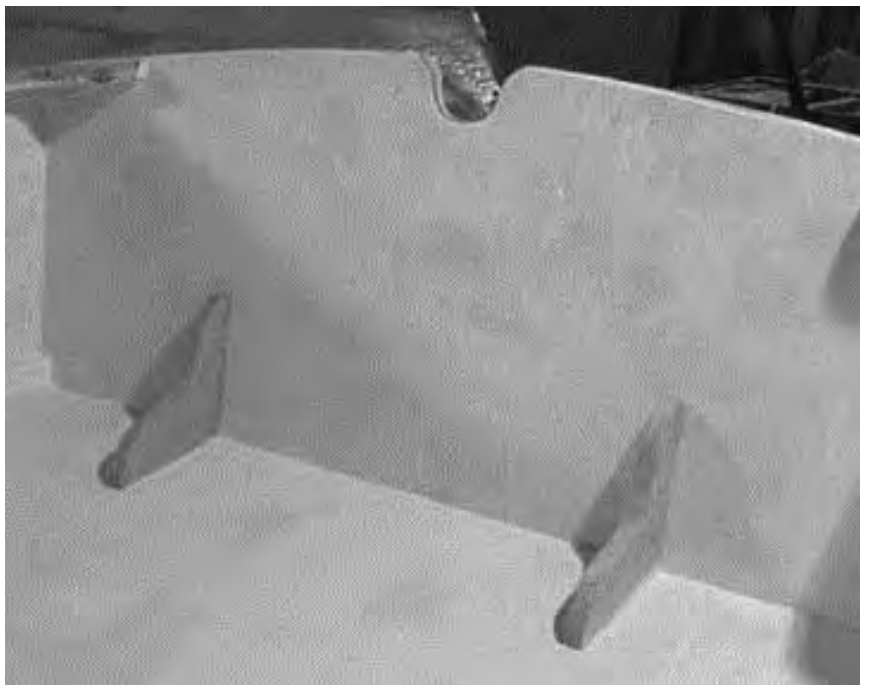
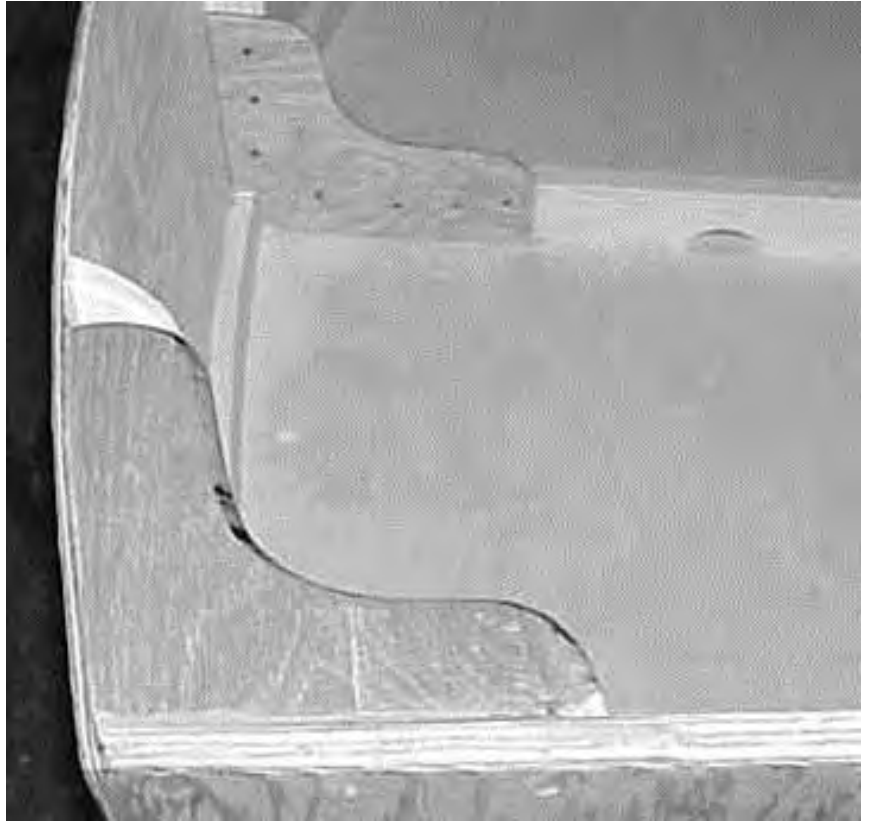

Installing the Outwales

The outwales are sometimes referred to as gunwales or “gun’ls”. It is simply (in this case) the rail that runs around the outside edge of the side panel at the sheer.

You can use mahogany, oak, spruce, or pretty much what you like here. You’ll need two strips of wood 1¼”x¾”x10’ long.

Beginning at the bow start clamping the outwale to the sheer with 2” spring clamps (you can’t have too many of these) and work your way aft to the stern. It will help tremendously if you have a helper. I’ve devised ways of doing such things by myself, but it’s always easier and faster if I have a helper.

The outwale should be flush with the top of the sheer as you clamp it up. That means you will be bending and torturing the wood a little. You should be able to bend it into position without steaming though.

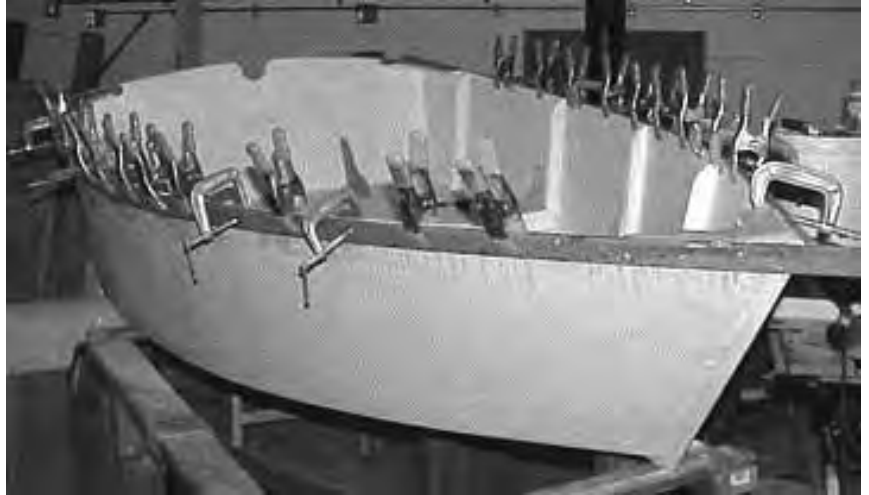

If the outwale does not fit flush with the sheer in places, try to adjust the clamps. If that won’t work and the you can’t get the surfaces to sit flush with each other, and they are less than a quarter of an inch off, it’s probably because the sides were not trimmed to match just right or they were not trimmed properly. This is not a problem. When the outwales are finally installed, you can make everything fit flush with your jackplane, and it will still look like it’s supposed to.

Now drill and countersink a #8x2” hole at each end of the outwale. Through the outwale, hull, and into the breasthook at the bow. Through the outwale, hull, and into the quarter knee at the stern. Then temporarily install the proper sized screw in each hole to hold the ends of the outwale in place. Drill, countersink, and temporarily install two #8x1½” stainless steel screws at each end, evenly spaced with the #8 wood screw at the quarter knee and breast hook.

Mark the inside hull panel about ½” or so below the sheer every 5 or six inches, and drill and countersink holes for #8x¾” stainless steel screws.

Remove the screws at the ends, unclamp and remove the outwale, and remove all the wood chips and sawdust.

Slather thickened epoxy on the inside surface of the outwale, and refasten into position. Use the clamps and large stainless steel wood screws at the ends. Install the #8x¾” stainless steel wood screws on the inside of the hull into the outwale.

Remove all the clamps and wipe off all the excess epoxy that has squeezed out. Trim off the excess outwale material beyond each end of the hull.

Fill in the screw holes with epoxy mixed with a sanding filler compound.

Repeat the whole process on the opposite side of the boat.

Fabricating and Installing the Motor Mount Pad (optional)

Simple Simon is really a rowing boat that can also be sculled quite easily. It rows with such little effort; I can't see why anyone would really want to put a motor on it.

There are those who will install an outboard regardless of what I have to say, so here is how to build and install a mounting pad for your outboard (See the section in this book on how to determine maximum horsepower).

Use a scrap piece of $\frac{3}{4}$ " plywood measuring 10" across and 8" deep.

Place the plywood against the inside of the transom at the centerline, with the top of the plywood flush with the top of the transom.

Mark the curvature of the transom onto the exposed inside face of the motor pad with a pencil.

Cut away the excess material from the motor pad with a saber saw or band saw.

Fit the motor pad into position with a couple of spring clamps.

Drill and countersink four evenly spaced screws (one in each corner) for #10x1½" wood screws and install stainless steel wood screws of that same size. Do not epoxy this piece into position, as you'll probably have to replace it in the future when the outboard motor mount screws chew it.

Installing Hardware

Note: You should fit the hardware as described below, but without the bedding compound. Then remove the hardware so that you can finish the hull. Then re-install the hardware permanently with bedding compound after final painting. You should also temporarily remove the thwarts to facilitate finishing the hull, and re-install them after painting.

You can install two sets of rowlocks (oarlocks) or you can just install one set. I recommend two sets as this allows you two rowing positions so it's easier to balance the boat when it's loaded down (as tenders often are).

By a rule of thumb, the oarlocks are generally located on the gunwale about 8" to 10" aft of the after edge of the thwart. You can decide where is best for you depending on your reach. If you have very long arms, mount them further away. You get the idea.

Most oarlocks have mounting brackets countersunk for wood screws.

You can mount your oarlocks this way if you wish to, however I suggest you drill through-holes straight through the gunwale and mount the oarlocks with machine screws and nuts. This will be a stronger mounting method, and will take more stress from rowing.

Use a bedding compound under the oarlock bracket before bolting it in place.

If you wish to mount a towing eye, locate a position about midway up the stem and drill the appropriate sized hole perpendicular to the stem. Mount the eye using bedding compound and a washer under the nut. It's much easier (and cheaper) to simply drill a hole in the stem, run a painter through the hole, and tie a stopper knot (figure eight knot) on the inboard side of the stem.

Make your hardware all bronze if you can afford it.

If you decide to add cleats, or fairleads anywhere, make sure they are also bronze (including the screws used to mount them), and that you always use bedding compound under the hardware.

Finishing the Hull

Start by sanding, and then sand some more, and sand yet again, and then just keep on sanding.

Start with around a #50 or #60 grit sandpaper to take off all the rough edges and epoxy runs, dribbles, etc. You can also round off a few edges on the quarter knees and breasthook if you haven't already done so.

Go to #80 grit and go over the rough spots again.

Completely sand the entire boat with #100 grit to 120 grit sand paper such that everything seems to blend at all your joints, and where panels meet components such as quarter knees, etc.

Brush off the hull and vacuum as clean as you can after sweeping up the shop, vacuuming the floor, and getting everything as dust free as you can.

Wipe down the entire boat inside and out with a couple of tack clothes.

Paint the entire hull with a clear sealer. This will help to seal the wood grain and keep the grain from getting "fuzzy". Let the sealer dry thoroughly.

Lightly hand sand the boat again with fine sand paper, or go over it with 3m abrasive pads. Go over the boat with a tack cloth again.

Paint with a water based exterior grade primer. I personally prefer to use Zinsser BIN123 Primer. Let dry and sand lightly with 150 to 180 grit. Wipe with tack cloth, and repeat this step again.

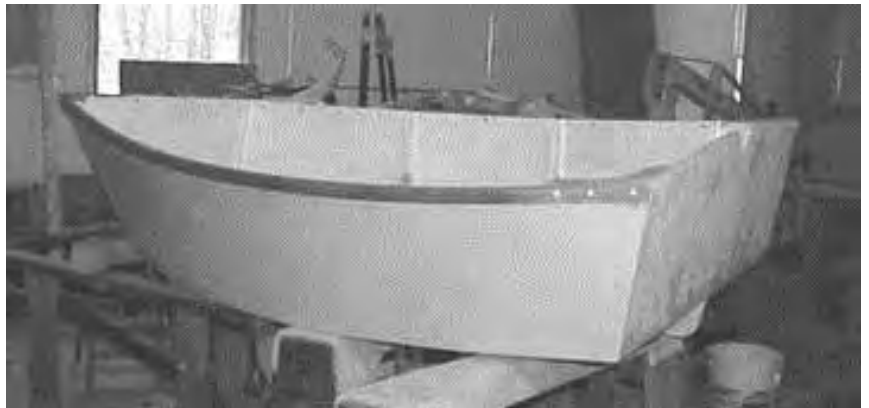

For finish paint, I regularly use latex based, exterior grade, porch & deck enamel. It stands up well for small dinghies and I buy what I call "oops" paint. This is paint that has been custom mixed for a customer by the local hardware or paint store, and the color was mixed incorrectly. This paint is often heavily discounted and a gallon can be purchased for around 8 or 9 bucks.

You may opt for more than one color for the top coat – that is up to you, but you'll follow the same procedure regardless: Apply the first coat lightly so you'll avoid any drips and runs. Allow this coat to harden before proceeding further.

Go over the hull with a 3m abrasive pad between coats, wipe with tack rag, and apply two additional coats for a total of three topcoats.

Re-install thwarts, hardware with bedding compound, and install a half-oval brass strip on the keel & skeg with

#6x1” stainless steel screws.

Congratulations. You’ve finally made it to the big launching day.

Launching

If you don’t mind, and remember to do so, please take a picture of your Simple Simon and send it to me here at the Shoestring Shipyard, located at 56 Shop Hill Rd. in Milbridge, ME 04658. We’ll add it to our scrapbook of home-built Simple Simon’s like yours.

Send notices to all of your close friends and relatives, and invite them down to your local pond, beach or launching ramp for the big day.

Make sure your boat has been inspected, titled and licensed (if required in your state).

Have your boat ready to go with all the required safety equipment on board (such as a bailing bucket, emergency signals, PFDs, horn, etc.).

Don’t forget the oars.

Get a couple of people to help put the stern in the water, with the bow on the beach, and then gather everyone around.

Say a few words, pour a little soda or sparkling water over the bow, a shot in the water as a token to Neptune, say a few magic incantations, take a swig, pass around the bottle, step in and shove off.

Have the local high school band present to play “Anchors Aweigh.”

Row around in a couple of circles, wave at the “crowd,” pose for pictures, then row on over the horizon – or something like that.

Here are a few photos of a Simple Simon built by high school shop teacher, Bob Leary at Falmouth High School, Falmouth, Massachusetts (Cape Cod). Note several custom details Bob added to the original design. The main change he made was adding a bit more curvature to the sheer. I think it really improves the looks of the boat:



Basic Materials List (for designed building method)

- 1 Sheet 4' x 8' x 1/4" AC Exterior or marine grade fir plywood
- 1 Sheet 4' x 8' x 3/8" AC Exterior or marine grade fir plywood
- 1 Sheet 4' x 8' x 3/4" AC Exterior or marine grade fir plywood.
- Two 2" x 4" x 8' building studs (Eastern Spruce, Douglas Fir, etc.)
- 18-8 stainless steel, flathead, self-tapping screws (or wood screws) of various lengths from 3/4" to 2" as needed (see text), all of which are #8 size screws. At least 12 stainless steel, #8 finish washers are also required.
- 3 quarts of mixed epoxy resin (1/2 gallon of epoxy resin and 1 quart of hardener if using a 2:1 ratio epoxy system)
- Calibrated epoxy dispensing pumps
- 1 quart of wood flour
- 1 quart of Cab-O-Sil
- 1 quart of micro-balloons
- Mixing cups
- Mixing/fillet sticks
- Latex gloves
- Epoxy user guide
- 14 yards of 3" wide, 9oz. Fiberglass tape
- Bow eye kit
- One pair of black nylon oarlocks
- Bedding compound (Phenoseal Caulk works well for this)
- 1 quart each of oil based primer and exterior porch & deck enamel
- Pair of oars, 6-1/2' long

Fastening Schedule

(Using 18-8 stainless steel, self tapping, flathead screws)

- Side panels to stem: #8 x 1" evenly spaced every 2" to 3"
- Side panels to main frame: #8 x 1", evenly spaced every 2" to 3"
- Side panels to transom: #8 #1" evenly spaced every 2" to 3"
- Bottom panel to transom: #8 x 1-1/4" evenly spaced every 2" to 3"
- Bottom panel to main frame: #8 x 1-1/4" evenly spaced every 2" to 3"
- Bottom panel to stem: #8 x 1-1/4" (only 1 or 2 screws)
- Bottom Panel to keel: #8 x 1" evenly spaced every 8" to 10"
- Skeg to keel: one screw (#8 x 1-1/4" or #8 x 1-1/2") at each end
- Outwale to hull: one #8 x 1-1/2" screw at each end per outwale
- Side panels to cleats: two or three screws (#8 x 1-1/4" or #8 x 1-1/2"), evenly spaced
- Thwarts to cleats: Two #8 x 1-1/2" or #8 x 2" screws with finish washers evenly spaced at each end of each thwart.

Simple Simon 8'

Designed By: Paul J. Bennett
(C) 2002, 2012 Shoestring Shipyard
All Rights Reserved

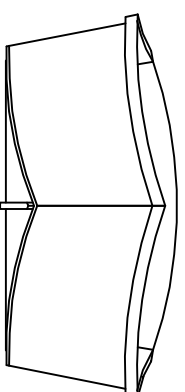
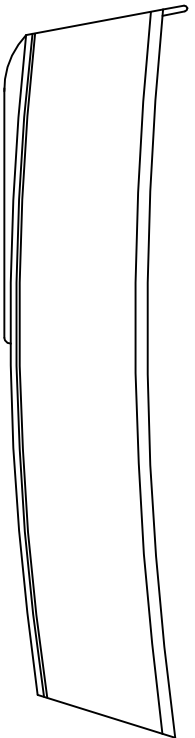
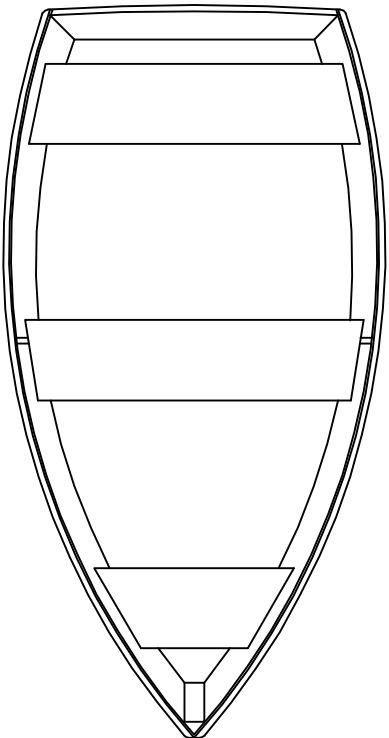

Scale: None

DWG # 558-001

Simple Simon 8'

DWG # 558-002

Main Frame

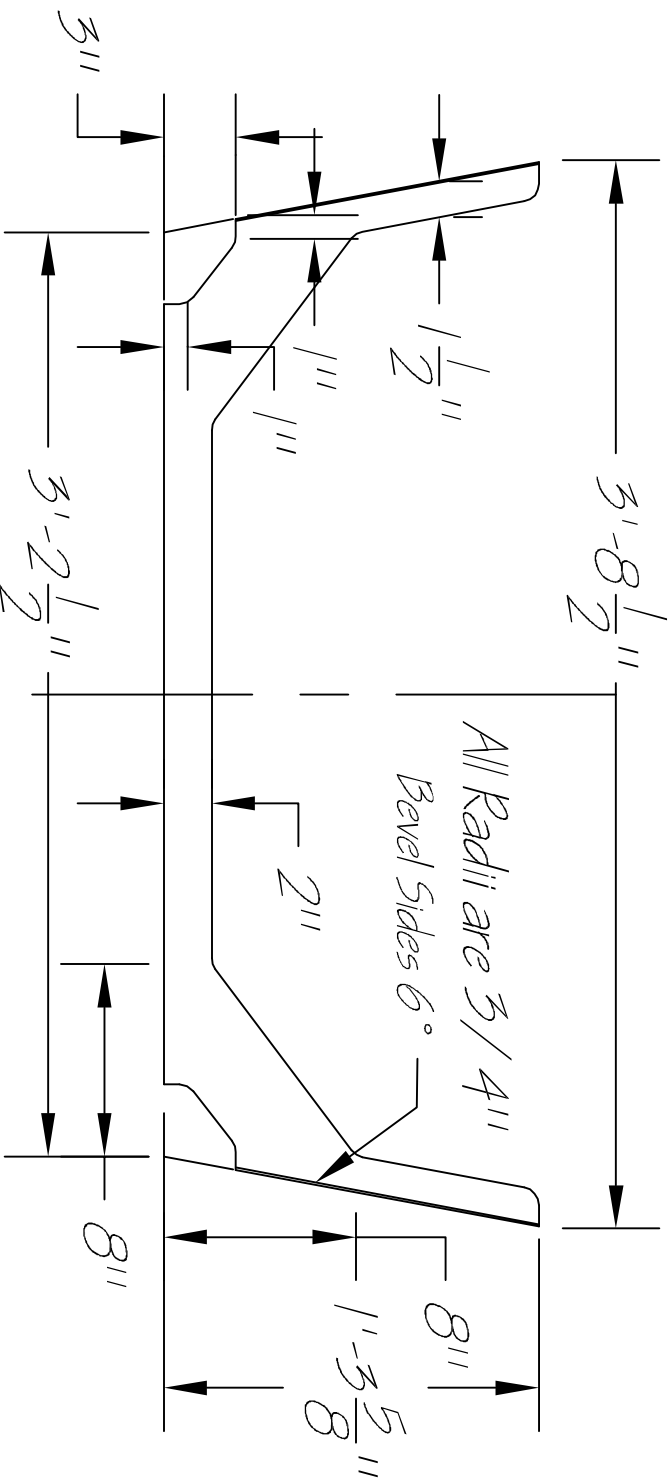

Note: Cut main frame from $3/4"$ ACX or marine ply

Designed By: Paul J. Bennett

(C) 2002, 2012 Shoestring Shipyard

All Rights Reserved

Scale: 1-1/2" = 1'

Simple Simon 8'

Note: Cut out both side panels from one 4'x8' sheet of plywood.

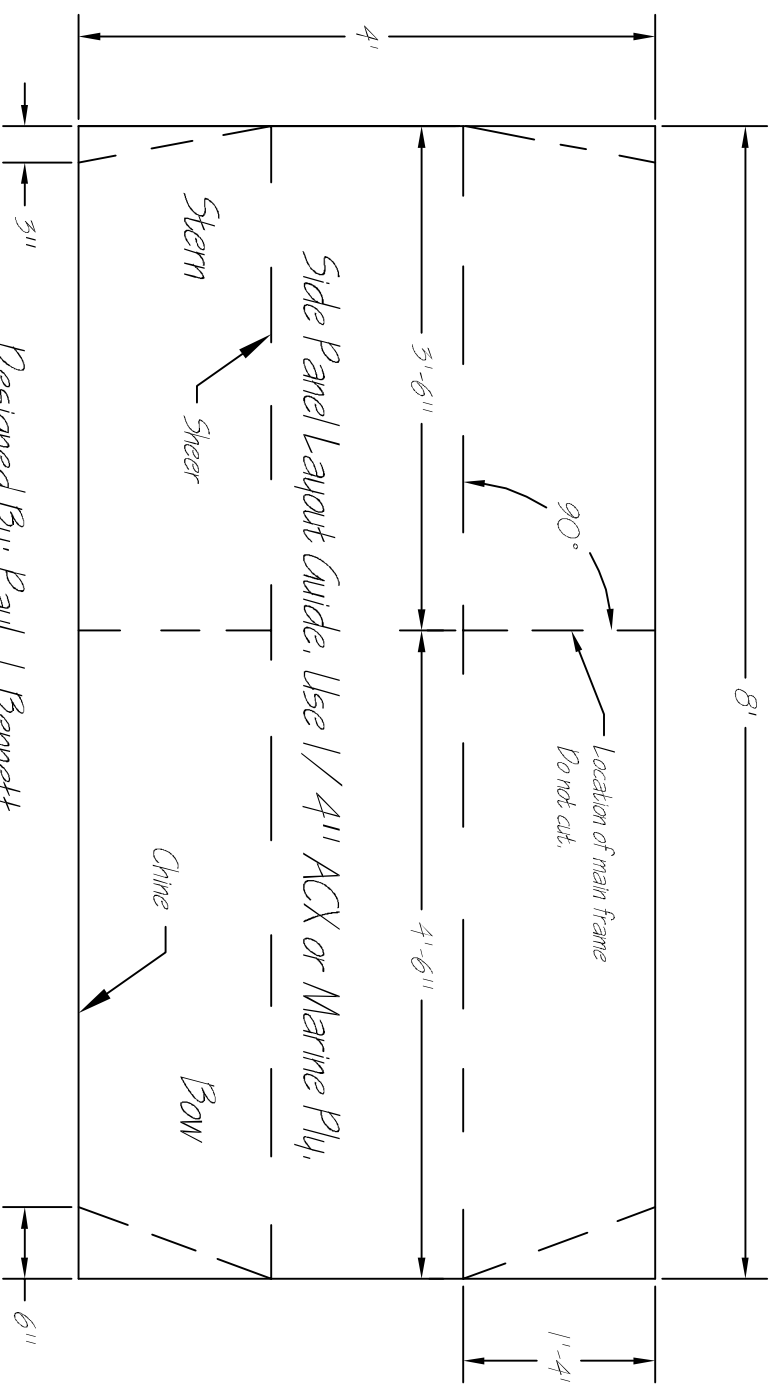

Side Panel Layout Guide. Use 1/4" ACX or Marine Ply.

Designed By: Paul J. Bennett
(C) 2002, 2012 Shoestring Shipyard
All Rights Reserved

DWG # 558-001

Scale: 3/4" = 1'

Simple Simon 8'

DWG # 558-004

Layout for Skeg

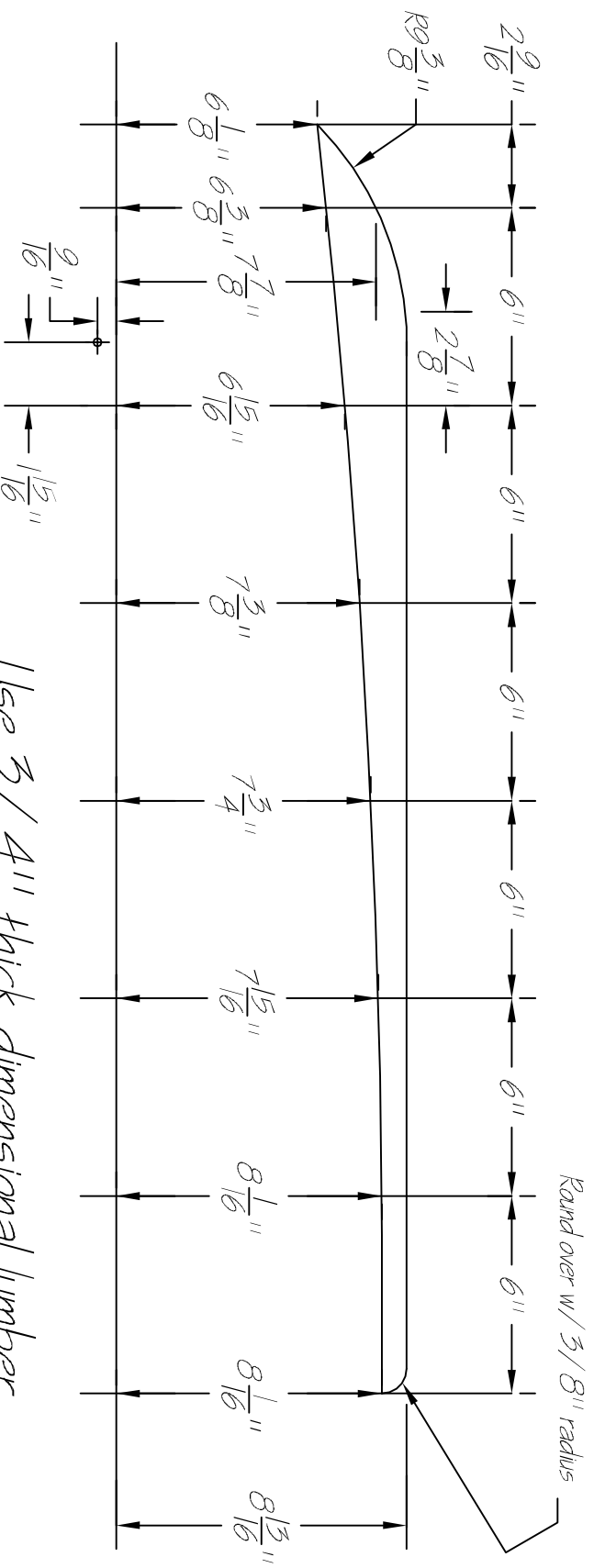

Use 3/4" thick dimensional lumber

Designed By: Paul J. Bennett

(C) 2002, 2012, Shoestring Shipyard

All Rights Reserved

Scale: None

Simple Simon 8'

BWG # 558-005

Stem

Top View

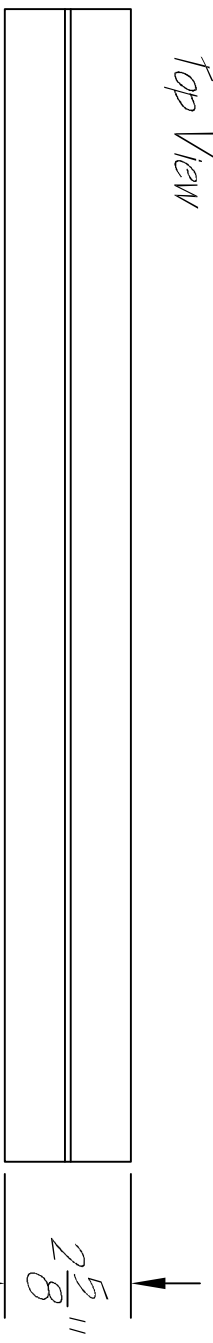

Set saw blade to 40° to cut stem bevel

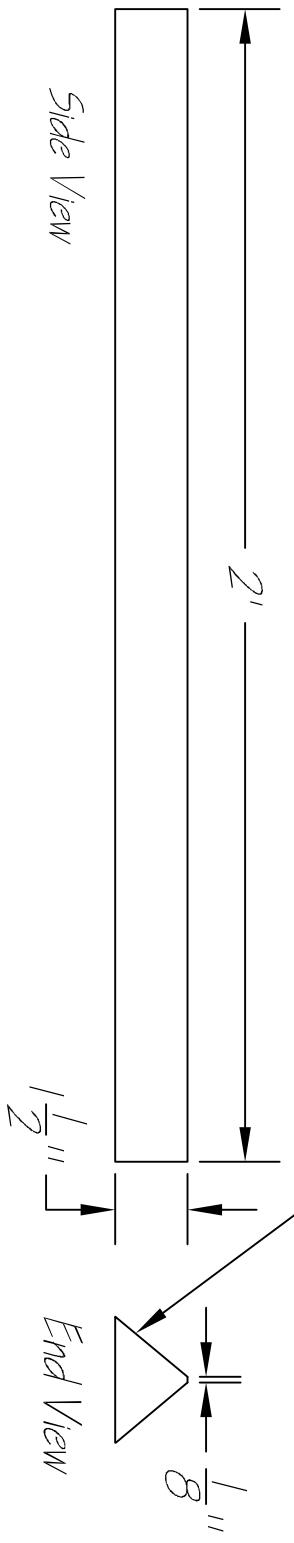

Side View

End View

Designed By: Paul J. Bennett

(C) 2002, 2012 Shoestring Shipyard

All Rights Reserved

Scale: 3" = 1'

Simple Simon 8'

Layout & cut transom from 3/4" ACX or marine ply.

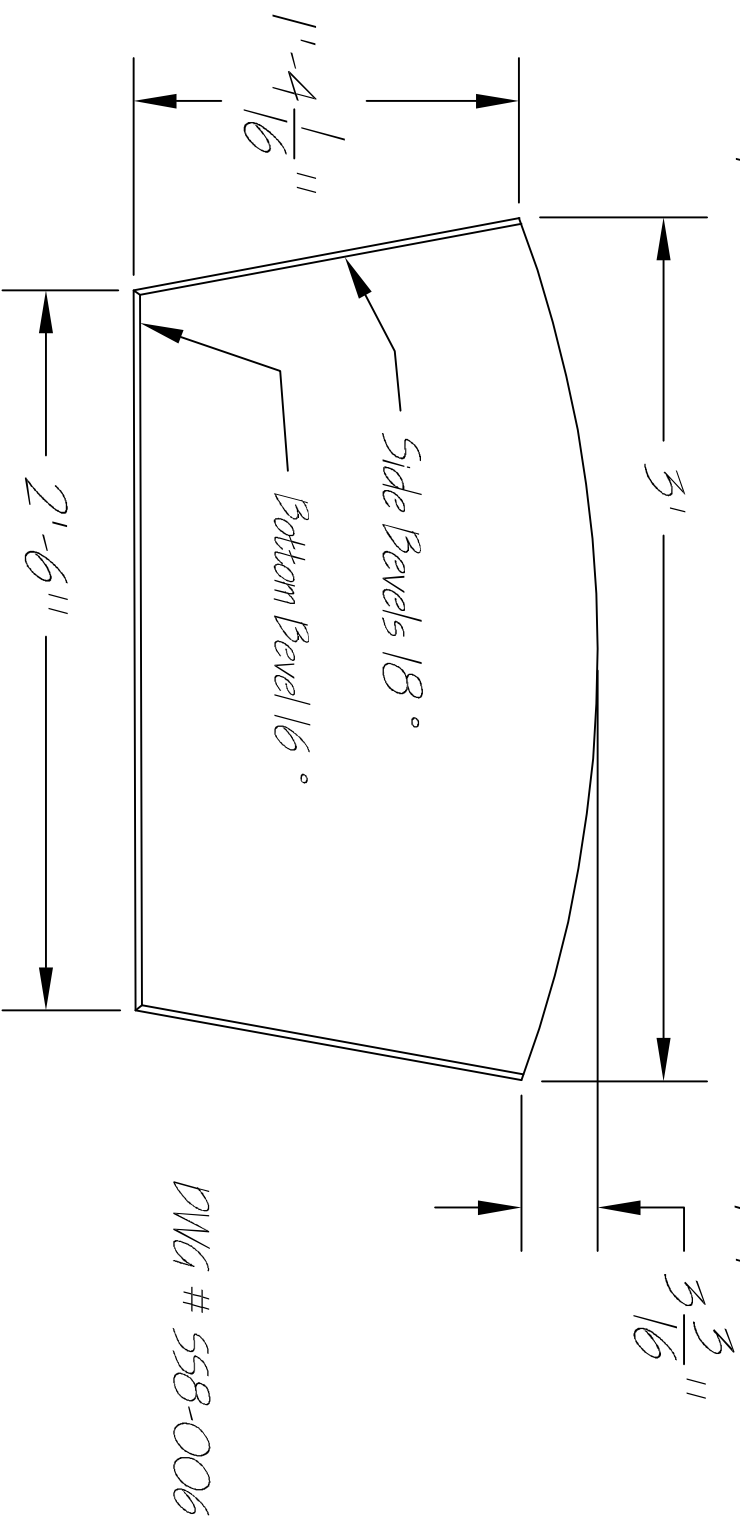

Designed By: Paul J. Bennett
(C) 2002, 2012 Shoestring Shipyard
All Rights Reserved

Scale: 1-1/2" = 1'

Simple Simon 8'

Dwg # 558-007

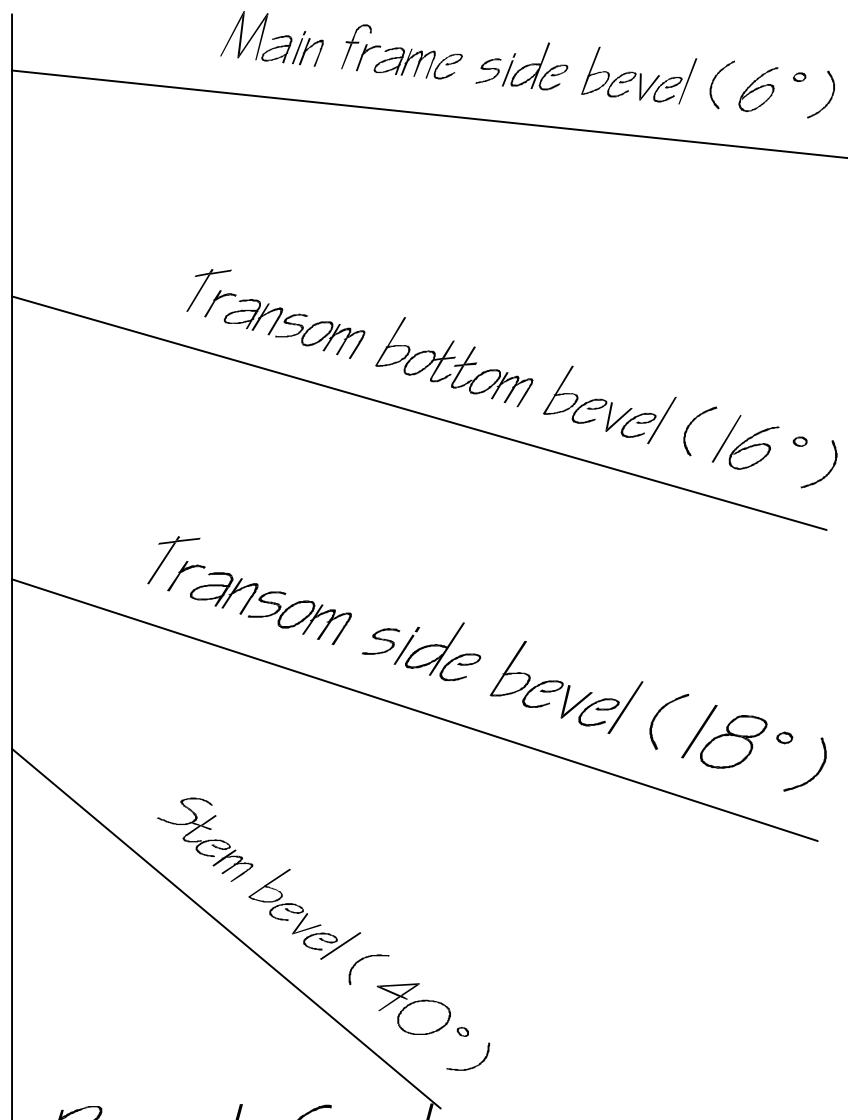

Bevel Guide

(For use with bevel gauge to set saw blades)

Designed By: Paul J. Bennett

(C) 2002, 2012 Shoestring Shipyard

All Rights Reserved

Scale: None

Chine Construction Details

Simple Simon 8'

BWG # 558-008

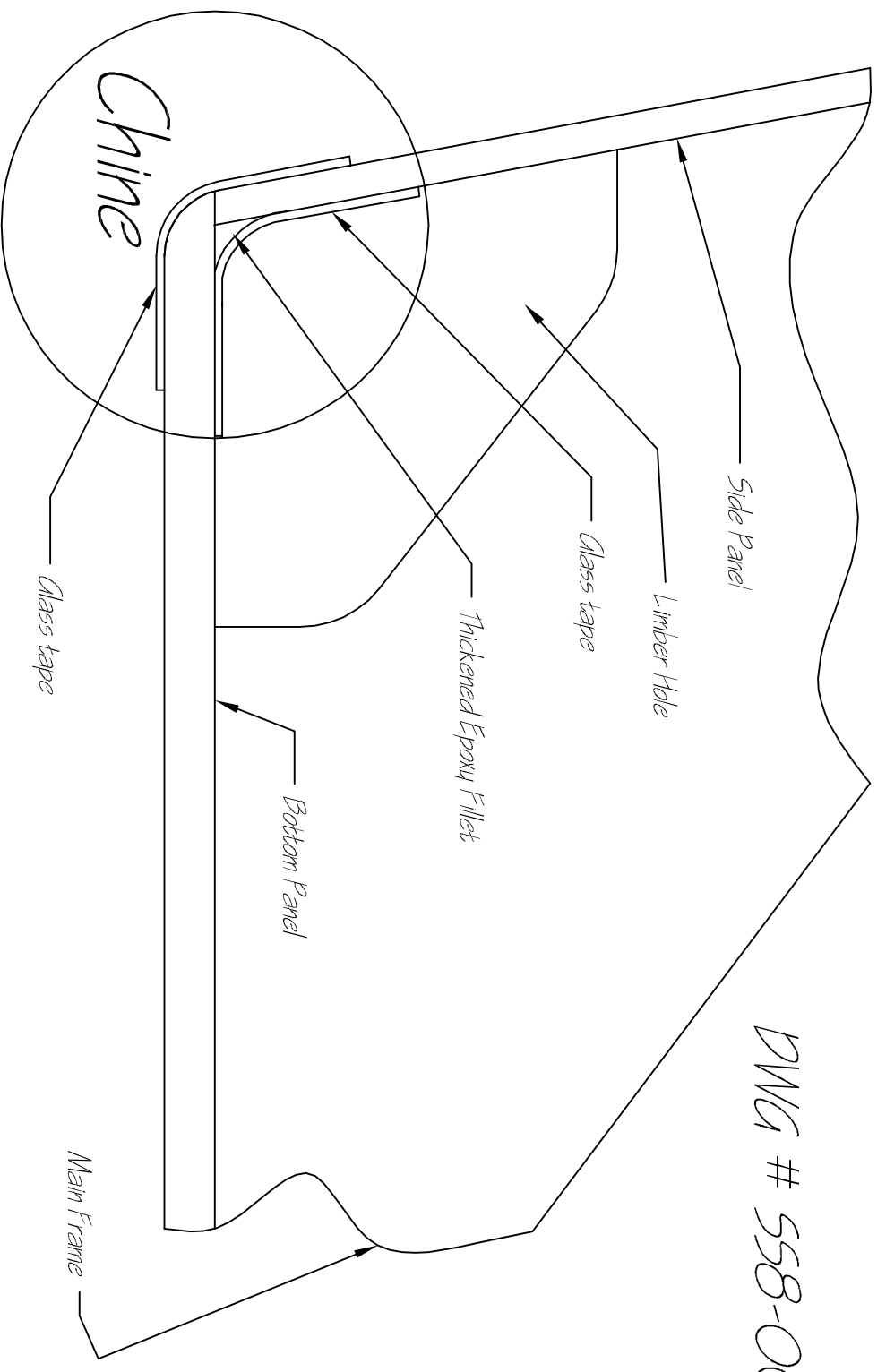

Designed by: Paul J. Bennett

(C) 2002, 2012 Shoestring Shipyard

All Rights Reserved

Scale: None

Simple Simon 8'

BWG # 558-009

Typical construction details (midship cross section)

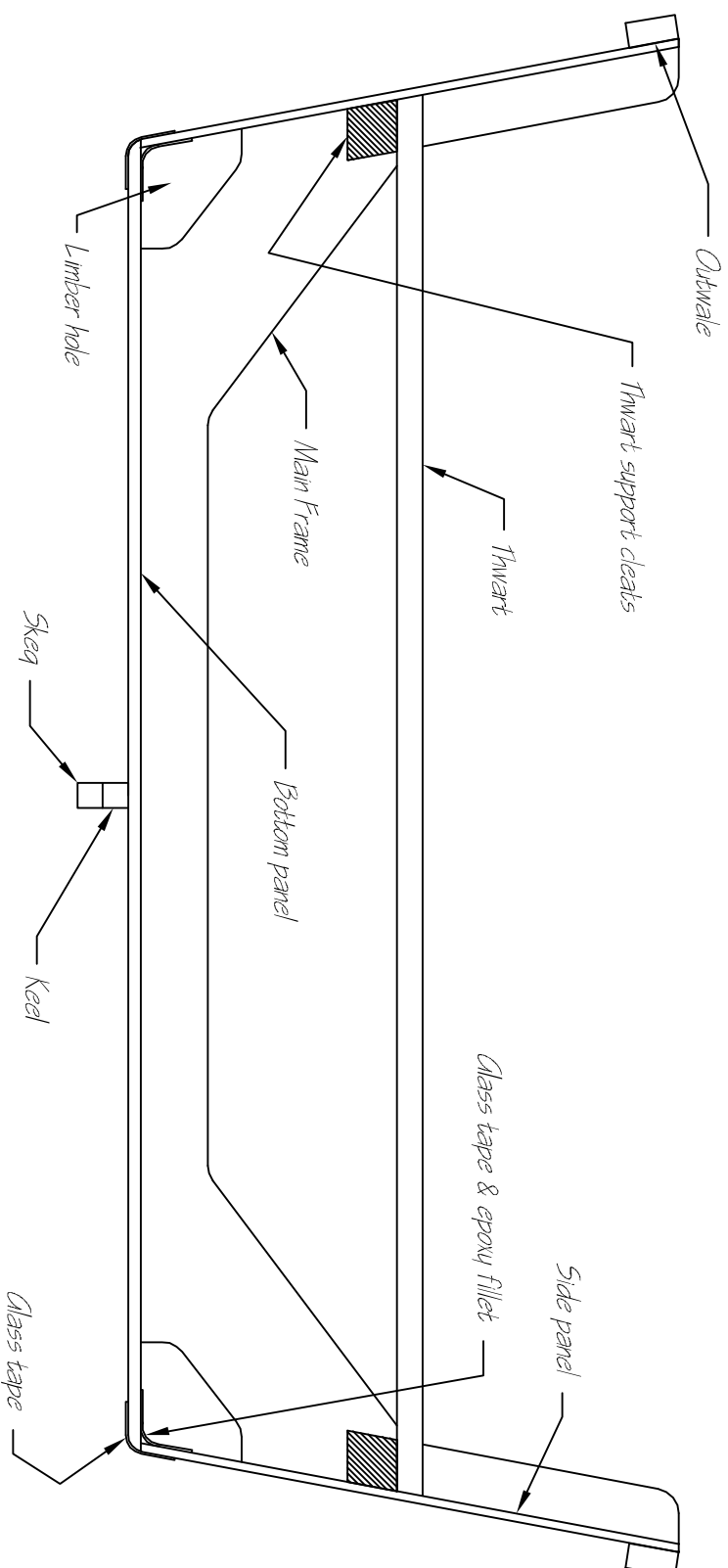

Designed By: Paul J. Bennett
(C) 2002, 2012 Shoestring Shipyard
All Rights Reserved

Scale: None

Data for Boat Building Materials

(Materials typically used in the construction of Shoestring Shipyard plywood skiff designs)

This section has been included to allow the builder to roughly calculate the weight of the boat he or she is building, and determine which material they may wish to use in the construction of their boat. It's not a very long section as it is not intended to be all inclusive. The materials discussed here are the most commonly used by builders of Shoestring Shipyard boats over many years. They are offered as food for thought and advance planning.

For folks intending to go well beyond our simple Shoestring Shipyard designs, there are several publications listed in the bibliography, dedicated entirely to the strengths, stresses, and properties of a wide variety of boat building materials.

The figures I have presented in this section are based upon a general average of figures taken from such publications mentioned above (none of them agree with each other). That's okay though. The weight of any kind of wood will vary with changes in humidity; the length of time a boat has been in the water (or out of the water). Weights of various woods will vary based on other variables as well, so don't get upset with me if your wood is a few pounds off either way from the figures I've presented here.

Shoestring Shipyard designs involve plywood in their construction, and in fact plywood makes up most of the material in each Shoestring Shipyard boat. It seems fitting then to begin with plywood, however this list only represents the most common sizes, and types of plywood commonly used.

Beginning with fir plywood, assume the same weight for either marine grade or exterior grade (the difference is in the quality of the veneers – the type of wood and glue are the same):

A standard sized 4' x 8' sheet of plywood has a total area of 32 square feet.

¼" x 4' x 8' sheet of fir ply = 25 pounds, or 0.78125 lbs/sq.ft.

3/8" x 4' x 8' sheet of fir ply = 37-1/2 pounds, or 1.1719 lbs/sq.ft.

½" x 4' x 8' sheet of fir ply = 50 pounds, or 1.5625 lbs/sq.ft.

¾" x 4' x 8' sheet of fir ply = 75 pounds, or 2.34375 lbs/sq.ft.

The weights given for fir plywood are nice to know, and most Shoestring Shipyard boats are built using this material (either exterior or marine grade). You may wish to use a more exotic (and more expensive) type of marine plywood though. Many folks do indeed build their boats using Okoume, marine grade plywood. I have built quite a few boats myself using this material, and I enjoy using it when I can afford it.

Okoume is made overseas and is given in metric measurements; however the figures cited below are the rough equivalent to US sizes (assuming close to 4' x 8' sheets):

- 6mm (1/4") sheet = 18 pounds, or 0.5625 lbs/sq.ft.
- 9mm (3/8") sheet = 28 pounds, or 0.875 lbs/sq.ft.
- 12mm (1/2") sheet = 37 pounds, or 1.15625 lbs/sq.ft.
- 18mm (3/4") sheet = 52 pounds, or 1.625 lbs/sq.ft.

As you may have noticed, Okoume is much lighter than fir by a significant margin. This is something worthy of your consideration based upon the type of boat you are building, and its intended use.

Sapele (there are variations on the spelling) is an African Mahogany. It is not as common to Shoestring Shipyard builders as fir and okoume, yet several Shoestring boats have been built using this material. Sapele is a marine grade plywood, very strong, and also quite expensive. Note it is significantly heavier than fir.

Sapele is a good choice for transoms, given its strength. Sapele also takes a beautiful, bright finish with marine grade spar varnish. Since this plywood is also manufactured overseas, it too is made in metric sizes. The equivalents are given below (assuming close to 4' x 8' sheets):

- 6mm (1/4") sheet = 28 pounds, or 0.875 lbs/sq.ft.
- 9mm (3/8") sheet = 42 pounds, or 1.3125 lbs/sq.ft.
- 12mm (1/2") sheet = 56 pounds, or 1.75 lbs/sq.ft.
- 18mm (3/4") sheet = 84 pounds, or 2.625 lbs/sq.ft.

For more information on other types of marine plywood not listed here, and to check prices; go to www.boulterplywood.com on the internet.

Boulter Plywood is located in Somerville, Massachusetts. They've been around since 1924, and they will ship plywood just about anywhere. They have been my supplier over many years and I've always received excellent service and fair value.

Dimensional Lumber

While most of a Shoestring Shipyard boat is plywood, dimensional lumber is also a very important ingredient, contributing to the structural integrity of the hull. Dimensional lumber is also used for styling effects, and provides a solid bite for screws holding plywood panels in place while epoxy resin cures.

My favorite wood species to specify for main frames, stems, keels, and other structural components is white oak. The problem associated with this wood is the expense, lack of availability in many communities, plus it is fairly heavy. I discovered using KD studs from the lumber yard (KD studs in the Maine are generally Eastern Spruce) work fairly well when building Shoestring designs. KD studs are much lighter, certainly cheaper, and easiest to find for most people.

The reason KD studs work well in the construction of a Shoestring Shipyard boat, is from the use of marine grade epoxy resins. The studs will hold screws during construction of the boat, holding the plywood in place as the epoxy cures. After curing, the plywood epoxy joint is very strong, and the screws are no longer needed.

If no epoxy was available or used while building a Shoestring boat, I would not recommend using KD studs because the wood is too soft to hold the screws and keep the boat together in a dynamic environment. The screws would eventually work or pull out, the plywood panels would pop off, and you would be treading water. Therefore, I highly recommend using marine grade epoxy resin if you are building with KD building studs or other softwoods in place of white oak or other dense hardwoods.

I've provided the approximate weight values below for a variety of common woods that are indigenous to various parts of the country. Once again, the list is not exhaustive, or all inclusive. It should prove useful to the majority of people building one of my designs, and have a burning desire to figure out the approximate weight of their boat.

When researching the weights of different wood species, I encountered figures which varied widely between book authors, and other sources. Rarely did I find any matches. Most differed by at least a few pounds in both directions. I took an average of three to four different specifications for each wood species, and used the average weight for my list below.

Hardwoods

White Ash – 42# per cubic foot – 3.5# per board foot

Honduran Mahogany – 34.5# per cubic foot – 2.875# per board foot

Philippine Mahogany (Luan) – 40# per cubic foot – 3.333# per board foot

White Oak – 47.5# per cubic foot – 3.96# per board foot

Okoume (Gaboon) – 26# per cubic foot – 2.17# per board foot

Teak – 44# per cubic foot – 3.67# per board foot

Softwoods

Alaska Cedar – 31.5# per cubic foot - 2.63# per board foot

Juniper – 22# per cubic foot – 1.83# per board foot

Northern White Cedar – 21# per cubic foot – 1.75# per board foot

Port Orford Cedar – 29# per cubic foot – 2.42# per board foot

Cypress – 33# per cubic foot – 2.75# per board foot

Douglas Fir – 35# per cubic foot – 2.92# per board foot

Hackmatack (Eastern Larch) – 35# per cubic foot – 2.92# per board foot

Eastern White Pine – 27.5# per cubic foot – 2.29# per board foot

Longleaf Yellow Pine – 42.5# per cubic foot – 3.54# per board foot

Eastern Spruce – 28.5# per cubic foot – 2.38# per board foot

Sitka Spruce – 27.5# per cubic foot – 2.29# per board foot

Fasteners

I generally specify the use of wood screws in the construction of my designs. This is because they provide the best holding power; important when the builder is not using a high quality, marine grade, epoxy resin system. The screws can be stainless steel or silicon-bronze, however you should stick with all stainless or all silicon-bronze. You cannot use a combination of the two without initiating electrolysis problems.

Stainless steel is my choice in most applications as it is stronger than silicon-bronze, and it is much less expensive. Silicon-bronze (in my opinion) is best suited for traditional plank-on-frame construction, where the fastener may have to be drilled out when removal & refastening becomes necessary. Use of stainless steel in such an application can create a nightmare during a hull refastening job.

For Shoestring Shipyard designs built using the glue-n-screw method of construction with quality, marine grade epoxy resin, I recommend using 18-8 stainless steel, Philips flat head, self-tapping screws in place of wood screws. Such screws are only needed as mini-clamps, holding plywood and other components in place until epoxy resin cures. These screws are much cheaper than traditional wood screws, and being stainless, they need not be removed after the epoxy cures.

Just for estimating purposes, I've listed the approximate weights of several different size 18-8 stainless steel, Philips flat head, self-tapping screws below per box of 100 screws. You can extrapolate the approximate weight for other sizes from this data, or you can contact marine materials sellers such as Sandwich Ship Supply, Hamilton Marine, or Jamestown Distributors for the information you need.

Screw Weights (per box of 100 screws)

#8 x ¾" = 6 oz.

#8 x 1-¼" = 8.4 oz.

#8 x 1-½" = 10.8 oz.

#8 x 2" = 13.0 oz.

#10 x 1" = 9.2 oz.

#10 x 1-¼" = 11.2 oz.

#10 x 1-¾" = 16.0 oz.

#12 x 1-¾" = 20.2 oz.

#12 x 2-½" = 25.0 oz.

Epoxy Resins

Regardless of which method of boat construction you may choose (glue-n-screw, or stitch-n-glue) to build a Shoestring Shipyard design, or similar designs, a high quality, marine grade, epoxy resin system should be used. Folks have a tendency to confuse epoxy with polyester resins. Epoxy resins and polyester resins differ substantially and are most certainly not compatible with each other, nor are they comparable.

Epoxy resins are formulated with solids. They are very strong after curing, and superior in all respects to polyester resins. Epoxy resins are also much more expensive than polyester resins, but well worth the price.

Polyester resins are typically used in fiberglass hull construction. They are relatively inexpensive, but do not have the strength characteristics required to achieve the strength and longevity of bonding power of holding a wooden boat together. Polyester resins also absorb water over time, and delaminating problems also eventually surface; which is

not the case with epoxy resins.

There are several types of epoxy resins as there are several manufacturers, however there are only a handful of manufacturers of high quality, marine grade epoxy systems.

Each epoxy system is different from another, and especially so when comparing each system between manufacturers. Most systems are not compatible with each other as they usually employ different mixing ratios and have differing chemical compositions. Therefore it makes sense to stay choose one manufacturer, and one epoxy system: Then stay with that system throughout the construction of your boat.

There are so many different types of epoxy systems, all with different specifications and instructions on use & application; it is well beyond the scope of this book to delve further into this subject. Each of the leading manufacturers of marine grade epoxy systems provides extensive information, user guides, instructions, and so forth – usually for free online. A Google™ search online will net a variety of manufacturers you can check out.

Perhaps the largest marine epoxy manufacturer with the most experience in this field is Gougeon Brothers, Inc. with their complete line of WEST System™ marine grade epoxy products. I have used their epoxy products for many years, always with excellent results. I highly recommend the use of Gougeon Brothers products, and as always: Seek out, read, and follow the manufacturer's instructions and recommendations. Contact information is in the back of this book.

If you should opt to use the WEST System™ line of epoxies, I have listed the approximate weights and coverage data below for estimating purposes.

“A” Size Containers

Resin and hardener combined = 1.2 qts. & 2.87 lbs. About 100 sq. ft. coverage when applied to porous surfaces and/or wetting out glass cloth.

This amount should be sufficient for most of the 8' dinghies in the Shoestring Shipyard fleet.

“B” Size Containers

Resin and hardener combined = 1.2 gal. & 11.36 lbs. About 375 sq. ft. coverage when applied to porous surfaces and/or wetting out glass cloth.

This amount may be sufficient for most other Shoestring Shipyard designs except for the Humble Peasant 22 or the Pilgrim's Pride. The Pilgrim's Pride may use twice this amount but will not require the “C” size containers.

“C” Size Containers

Resin and hardener combined = 5.8 gal. & 53.82 lbs. About 1600 sq. ft. coverage when applied to porous surfaces and/or wetting out glass cloth.

This amount (at least) may be sufficient for building the Humble Peasant 22, depending on which version is being built. More may be necessary.

General Epoxy Comments

All epoxy resin and hardener systems have a limited shelf life. Therefore it is probably best to purchase quantities you know you will use within a reasonable amount of time so the product stays fresh.

Most epoxies will clean up with acetone solvent before they set up in the curing process, so spills and drips should be cleaned right away. Use gloves and other protection such as goggles as epoxy resins are carcinogenic, and the acetone solvent can do bad things to your body too – read the warnings on the container, and keep this stuff out of the hands of children. Acetone is highly flammable – something else to keep in mind when using it.

I have not listed weights of various epoxy fillers because the amount you might use in the construction of your boat is negligible given the wide variance in the various weights of other boat building materials used in your weight calculations.

Fiberglass Cloth & Tape

Fiberglass cloth comes in a variety of thickness; however the thickness of the cloth is not specified. The cloth is classified by weight. You may see a specification for 6oz. or 10oz. fiberglass cloth. This means the cloth weighs 6oz. per square yard or 10oz. per square yard, respectively. Obviously, the 6oz. cloth is thinner (being lighter) than the 10oz. cloth. The heavier cloth will use more epoxy resin when wetting out with the first epoxy coat application.

Fiberglass tape is really nothing more than a thin strip of fiberglass cloth wound up into a roll. It is very handy for covering plywood seams and adding strength to filleted joints without having to cut strips from a sheet of fiberglass cloth. The fiberglass tape is simply rolled out to the desired length and cut from the roll. This saves a lot of time and labor. The tape is classified by weight in the same manner as fiberglass cloth and is available in a number of various widths. Rolls are most commonly purchased by the linear yard in quantities of 25 yards, 50 yards, and 100 yards.

Most Shoestring Shipyard designs specify either 6oz. or 10oz. fiberglass cloth or tape weights. Therefore the following data is offered for your estimating purposes.

6oz. Fiberglass Cloth or Tape:

This means 6 ounces per square yard. There are 9 square feet in one square yard, so 1 square foot of 6oz. cloth or tape weighs .667 oz. per square foot.

10oz. Fiberglass Cloth or Tape:

This means 10 ounces per square yard. There are 9 square feet in one square yard, so 1 square foot of 10oz. cloth or tape weighs 1.11 oz. per square foot.

Primers, Paints, Varnish, and Other Coatings

I do not typically offer any specifications for coatings or finishes used in Shoestring Shipyard boat designs. The differences between densities (weights), number of coats required, and square foot coverage per gallon vary significantly. It's best for the builder to make inquiries of the manufacturer in order to acquire this information. Of course it is prudent to read the print on the paint can first, as you may find all the information you need without going any further.

Hardware

The hardware you choose to outfit your boat is another source of variables in terms of materials types and weights.

You can simply weigh the hardware yourself if you already have it, or you might extrapolate the weight of an item from a marine suppliers catalog or web site. Depending on how big your boat is, the weight of the hardware and/or equipment can be significant in the total weight and trim of your boat when it is finished and ready for the water.

Final Thoughts on Materials and Hull Weight Estimating

After you have completed your estimate on how much your new boat will weigh based on the materials and hardware you've chosen, it would be interesting to see just how close your estimate actually is. It's quite easy for small boats under 8' in length. They are usually light enough for an adult to pick up and put on a scale. You can then read the actual weight from the scale and compare it to your estimated numbers.

If you are within 10% of your estimate, I might want to consider hiring you. If you are within 20% of your estimate, that's not bad at all given the variables you had to contend with. If you are beyond 20% of your estimate, you probably missed something in your estimate somewhere, or perhaps made a simple math error.

Bigger boats require more effort. The direct weighing on a scale method can be employed if you have a big enough scale and at least two adults for boats up to around 12' in length. Larger boats require a trailer, a vehicle to pull the trailer with, and a truck stop with a commercial truck scale. This requires two weigh-ins. Top off the fuel tank of your vehicle before weighing, then pull onto the scales with the truck and empty trailer, then have the Weigh-Master record your weight. Put your boat on the trailer, make sure your fuel tanks on the truck is topped off again, and have the truck stop Weigh-Master record your second weight. Subtract the first weight reading from the second, and you'll have a fairly accurate weight for your boat.

Determining Maximum Allowable Horsepower

If you are building a boat for use with an outboard motor, you can figure out what the legal maximum horsepower rating is for a flat bottomed, hard chined skiff. USCG regulations, as stated in Title 33 CFR, Part 183, Subpart D, require maximum horsepower to be determined for "monohull boats less than 20 feet in length, except sailboats, canoes, kayaks, and inflatable boats that are designed or intended to use one or more outboard motors for propulsion."

To find maximum outboard motor power capacity: Multiply overall length in decimal feet by the maximum transom width in decimal feet. This gives you a number referred to by the USCG as a "factor." (You round off to the nearest whole number). If the factor is within 35, the max hp is 3hp. Factor 36-39=5hp. Factor 40-42=7-1/2hp. Factor 43-45=10hp. Factor 46-49=15hp. Factor 50-52=20hp. Factors over 52 for flat bottomed, hard chined boats are divided by 2 (divided in half) and then subtract 15 and that gives you the maximum horsepower.

For example: The Pilgrims Pride 16 has a length overall of 15'4" and a maximum transom width of 6'. To determine max horsepower, first multiply 15.333 times 6 resulting in a factor of 91.998 and rounded to the nearest whole number yields a factor of 92. One half of 92 is of course 46, and minus 15 is 31 which results in a max hp rating of 31hp. As a general rule, I specify around 80% of the USCG max hp for a number of reasons I won't get into here, so you'll notice that on the Shoestring web site, I've specified 25hp as maximum for the Pilgrim's Pride 16.

I used this boat as an example as it was specifically designed for use with an outboard motor. If the factor does not exceed 52, you do not have to divide the factor in half or subtract anything – simply refer to the hp specs for the factor numbers I gave you above.

Construction Details

The next few drawings show various tips and suggestions you might adopt during the construction of your boat.

Plyson Scarf Joint

DWG - DD-1

Drawn by: Paul J. Bennett, (C) 2002, 2012, All Rights Reserved

Step (1) : Butt plywood edges together.



Step (2) : Grind out wood along edges about 2" back from edge.
Grind to a depth of about 1/3 thickness of plywood.

Scale = None



Step (3) : Fill cavity with fiberglass tape and thickened epoxy.

Repeat Step (2) on opposite side of ply after the first side has cured.

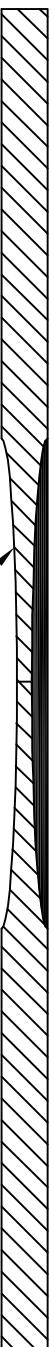

Step (4) : Repeat Step (3) on opposite side of plywood.

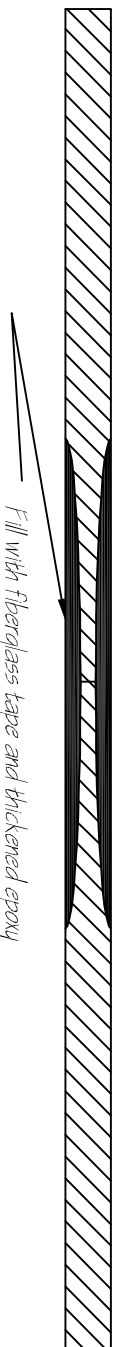

REVISIONS				
ZONE	REV	DESCRIPTION	DATE	APPROVED

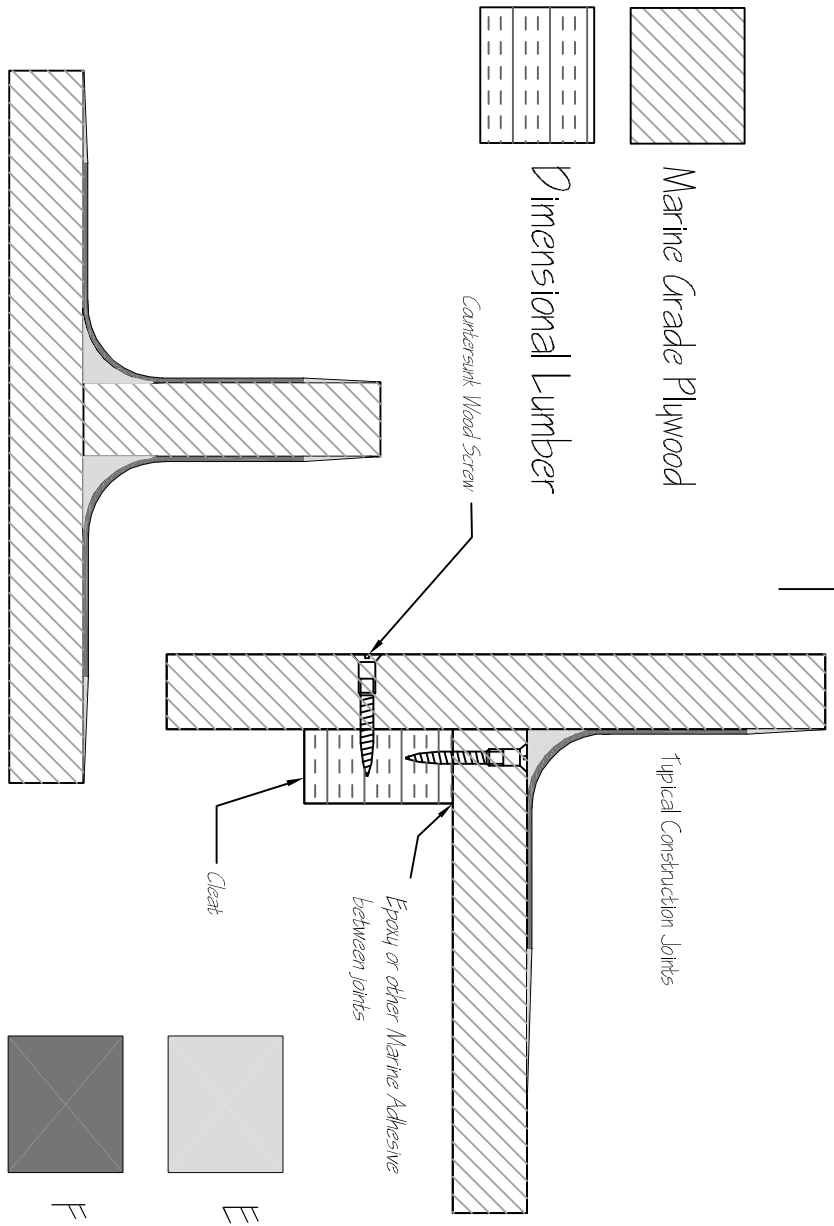

Designed by:
Paul J. Bennett

Shoestring Shipyard

Typical Construction Joints

(C) 2002, 2012

SIZE: FSCM NO.: DWG NO.: REV:

SCALE: None

DD-2

PP-2

None SHEET

All Rights Reserved

USER

REVDATE

FNAME

Designed By: Paul J. Bennett		Shoestring Shipyard	
(C) 2002-2009, 2012		Stitch-N-Glue Details	
All Rights Reserved		SIZE	REV
		FSCM NO.	DD-3
		DWG NO.	
		SCALE None	SHEET

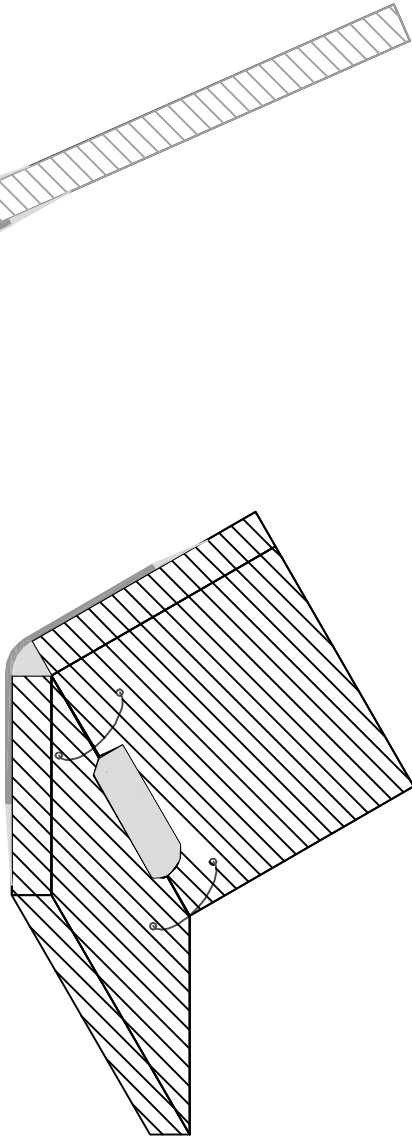

Epoxy Resin thickened with fillers

Typical Stitch-N-Glue Construction

Epoxy Resin and Fiberglass Tape

Marine Plywood



Shoestring Shipyard

Scale: None

DD-8

Typical Floatation for Skiffs

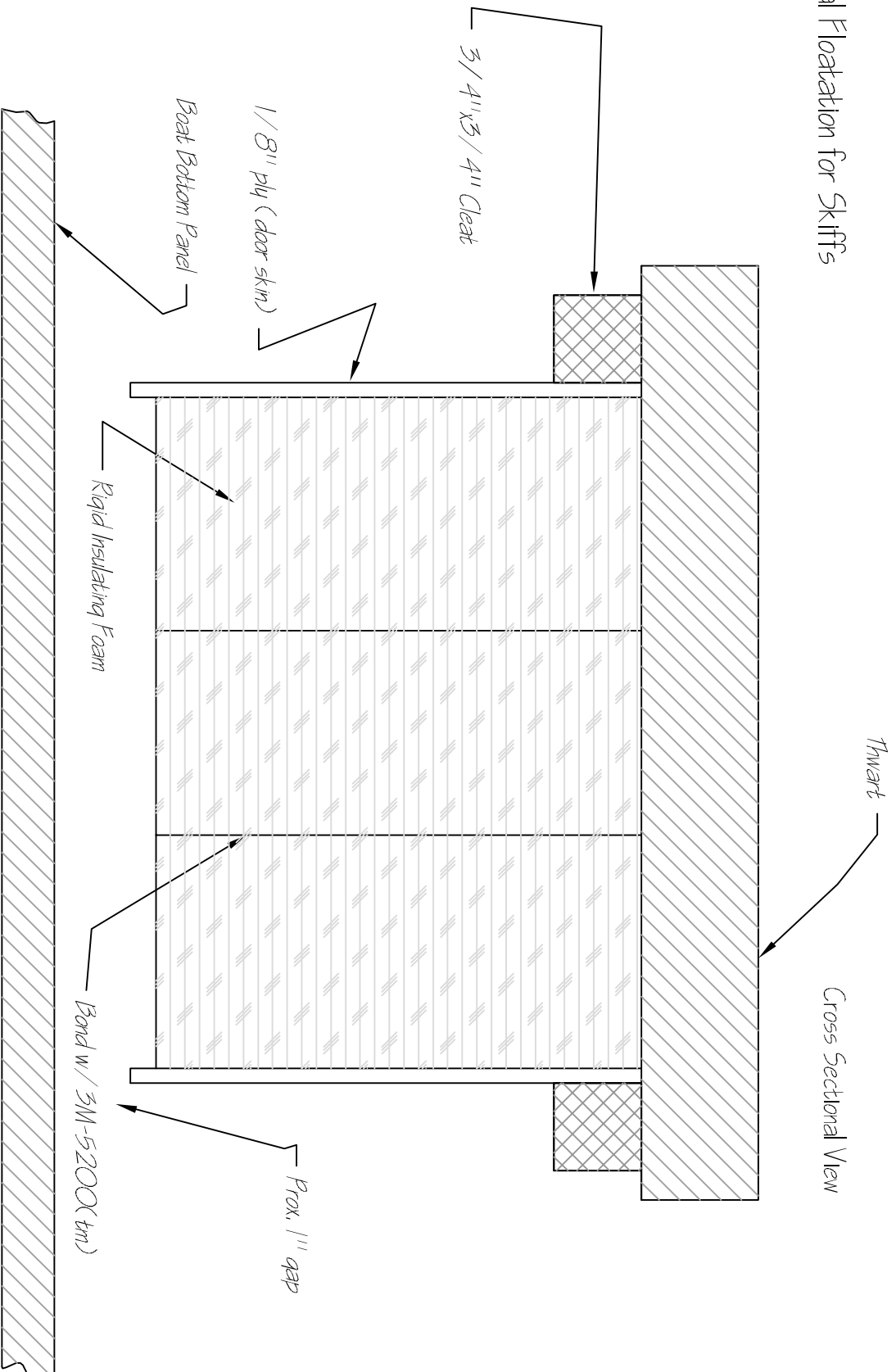

Designed by: Paul J. Bennett

(C) 2003, 2012

All Rights Reserved

Bibliography

- American Boat and Yacht Council, Inc. Standards and Recommended Practices for Small Craft. Amityville, NY: American Boat and Yacht Council, Inc.
- Gougeon, Meade. The Gougeon Brothers on Boat Construction: Wood & WEST System Materials. Bay City, Michigan: Gougeon Brothers, 1985.
- Gerr, Dave. Boat Strength: for Builders, Designers, and Owners. Camden, ME: International Marine, 2000
- Gerr, Dave. The Nature of Boats: Insights and Esoterica for the Nautically Obsessed. Camden, ME: International Marine, 1995
- Witt, Glen L. & Hankinson, Ken. Boat Building with Plywood. Bellflower, CA: Glen-L Marine Designs, 1978
- Nicolson, Ian. Boat Data Book: Fourth Edition. Dobbs Ferry, NY: Sheridan House, Inc., 1999
- Chapelle, Howard. American Small Sailing Craft: Their Design, Development, and Construction. New York, NY: W.W. Norton & Co., 1951
- Chapelle, Howard. Yacht Designing and Planning. New York, NY: W.W. Norton & Co., 1971
- Kinney, Francis S. Skene's Elements of Yacht Design. (8th Edition, 6th Printing). New York: Dodd, Meade, and Company, 1981
- Larsson, Lars & Eliasson, Rolf E. Principles of Yacht Design. Camden, ME: International Marine, 1994
- McIntosh, David C. How to Build a Wooden Boat. Brooklin, ME: WoodenBoat Publications, Inc., 1987
- Gardner, John. Building Classic Small Craft: Volume I. Camden, ME: International Marine, 1991
- Trower, Gordon. Yacht and Small Craft Design: From Principles to Practice. Ramsbury, Marlborough Wiltshire, UK: Helmsman Books, 1995
- Hammitt, Andrew G. Technical Yacht Design. New York: Van Nostrand Reinhold Company, 1975
- Tupper, Eric. Introduction to Naval Architecture. Jersey City, NJ: Society of Naval Architects and Marine Engineers (SNAME), 1996
- Hamlin, Cyrus. Preliminary Design of Boats and Ships. Centreville, MD: Cornell Maritime Press, Inc., 1989
- Steward, Robert M. Boatbuilding Manual: Fourth Edition. Camden, ME: International Marine, 1994
- Graves, Garth. Yacht Craftsman's Handbook. Camden, ME: International Marine, 1992
- Butz, Richard. Building the Six Hour Canoe. St. Michaels, MD: Tiller Publishing, 1994
- Monk, Edwin. How to Build Wooden Boats: With 16 Small Boat Designs. New York: Dover Publications, Inc., 1992
- Rabl, Sam S. Boat Building in Your Own Backyard. Centreville, MD: Cornell Maritime Press, 1995
- Farmer, Weston. From My Old Boat Shop. Portland, Oregon: Boat House, 1996
- Nicolson, Ian. Build Your Own Boat. New York: W.W. Norton & Company, 1982
- Payson, Harold H. Instant Boats. S. Thomaston, ME: Payson & Co., 1995
- Greenwell, David K. Small Boat Building. Ramsbury, Marlborough Wiltshire, UK: The Crowood Press, LTD., 1997
- Bolger, Philip C. Boats with an Open Mind. Camden, ME: International Marine, 1994
- Parker, Reuel B. The Sharpie Book. Camden, ME: International Marine, 1994
- Bingham, Fred P. Boat Joinery & Cabinetmaking Simplified. Camden, ME: International Marine, 1993
- Devlin, Samuel. Devlin's Boat Building. Camden, ME: International Marine, 1996
- Buehler, George. Buehler's Backyard Boatbuilding. Camden, ME: International Marine, 1991
- Vaitses, Allan H. Lofting. Brooklin, ME: WoodenBoat Publications, 1999
- Rabl, Sam S. Ship and Aircraft Fairing and Development: For Draftsmen and Loftsmen and Sheet Metal Workers. Centreville, MD: Cornell Maritime Press, 1994
- Edmunds, Arthur. Designing Power & Sail. Enola, PA: Bristol Fashion Publications, 1998
- Bolger, Philip C. 100 Small Boat Rigs. Camden, ME: International Marine, 1984
- Brewer, Ted. Understanding Boat Design: 4th Edition. Camden, ME: International Marine, 1994
- Stambaugh, Karl. Good Skiffs: How they're Designed and Built. Marblehead, MA: Devereux Books, 1998

- Jones, Thomas Firth. *New Plywood Boats: and a Few Others*. Dobbs Ferry, NY: Sheridan House, 2001
- Gardner, John. *The Dory Book*. Mystic, CT: Mystic Seaport Museum, 1987
- Thomas, George B. *Calculus and Analytic Geometry*. Reading, MA: Addison-Wesley Publishing Company, Inc., 1972
- Payson, Harold. *Build the New Instant Boats*. Camden, ME: International Marine, 1986
- Greene, Danny. *Cruising Sailboat Kinetics: The Art, Science, & Magic of Cruising Boat Design*. St. Michaels, MD: Tiller Publishing, 1997
- Gardener, John. *Wooden Boats to Build and Use*. Mystic, CT: Mystic Seaport Museum, 1996
- Bingham, Bruce. *The Sailor's Sketchbook*. Camden, ME: International Marine, 1983
- Willis, Melvin D. C. *Boatbuilding and Repairing with Fiberglass*. Camden, ME: International Marine, 1983
- Sears, Zemansky, Young. *University Physics – Fifth Edition*. Reading, Massachusetts: Addison-Wesley Publishing, 1977
- Roberson/Crowe. *Engineering Fluid Mechanics – Second Edition*. Boston, MA: Houghton Mifflin Company, 1980
- Ross, Shepley L. *Introduction to Ordinary Differential Equations – Third Edition*. New York: John Wiley & Sons, Inc., 1980
- Bohm & Jensen. *Build Your Own Underwater Robot; and Other Wet Projects*. Vancouver, B.C. Canada: Westcoast Words, (10th printing) 2010
- Welchons/Krickenberger/Pearson. *Plane Geometry*. Lexington, MA: Ginn & Co., 1969
- Welchons/Krickenberger/Pearson. *Solid Geometry*. Boston, MA: Ginn & Co., 1959
- Rice/Knight. *Technical Mathematics*. New York, NY: McGraw-Hill, 1963

